

■ FRONT AND REAR BRAKES

- Aluminum monoblock opposed piston type front and rear brake calipers are used, achieving both high-rigidity and a reduction in weight.
- 6-piston calipers are used for the front brakes, with 2-piston calipers for the rear.
- High friction pads are installed for the front and rear brakes in order to achieve high brake performance and excellent brake feeling.
- Front and rear drilled rotors with pillar type fins are used to ensure cooling and stable brake performance.

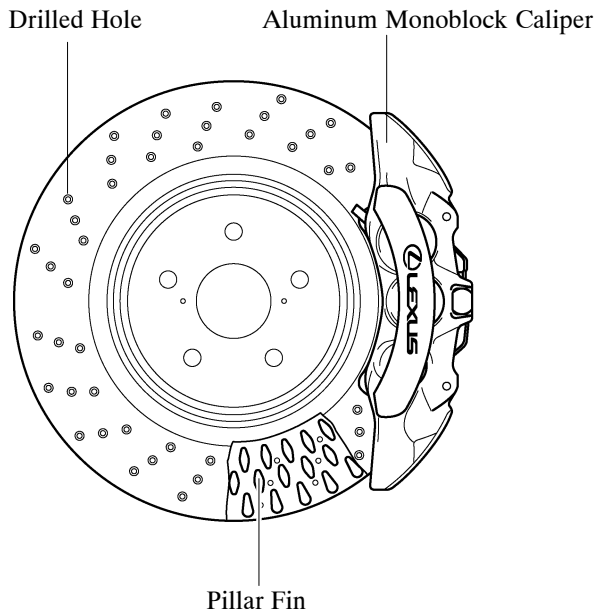

Front Brake

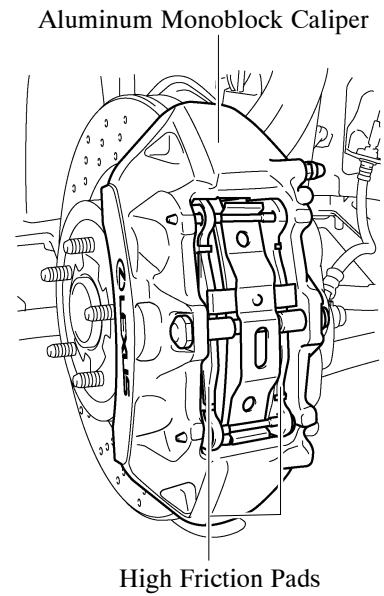

08D0CH27C

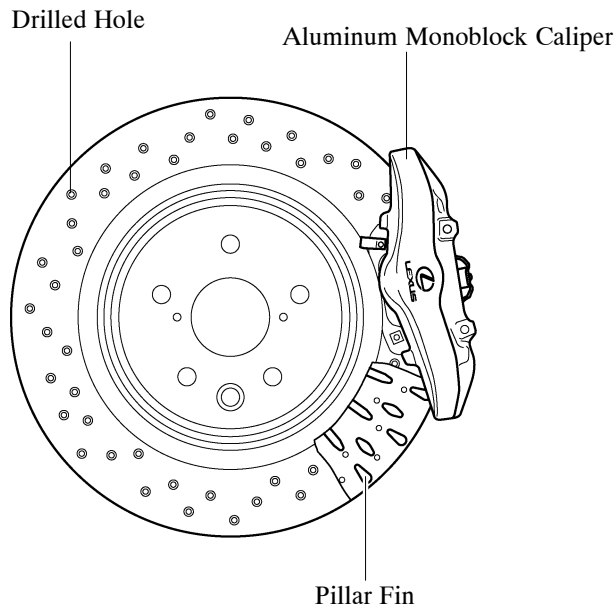

Rear Brake

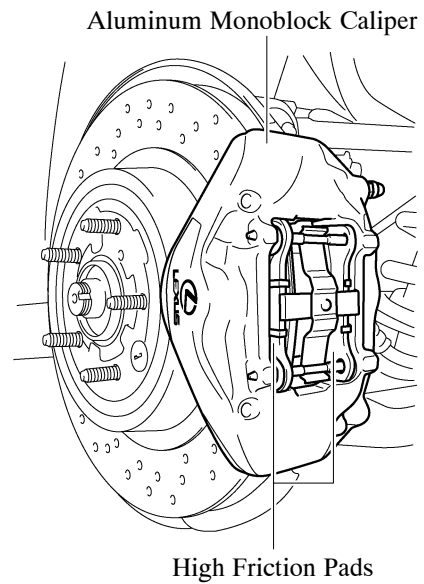

08D0CH28C