

Engine Workshop Manual SKYACTIV-G 2.5T

FOREWORD

This manual explains the service points for the above-indicated automotive system. This manual covers all models with the above-indicated automotive system, not any one specific model.

In order to do these procedures safely, quickly, and correctly, you must first read this manual and any other relevant service materials carefully.

All the contents of this manual, including drawings and specifications, are the latest available at the time of printing. As modifications affecting repair or maintenance occur, relevant information supplementary to this volume will be made available at Mazda dealers. This manual should be kept up-to-date.

Mazda Motor Corporation reserves the right to alter the specifications and contents of this manual without obligation or advance notice.

All rights reserved. No part of this book may be reproduced or used in any form or by any means, electronic or mechanical—including photocopying and recording and the use of any kind of information storage and retrieval system—without permission in writing.

**Mazda Motor Corporation
Hiroshima, Japan**

CONTENTS

Title	Section
GENERAL INFORMATION	00
ENGINE	01

© 2015 Mazda Motor Corporation
Printed in the U.S.A., December 2015
Form No. 1A99-1U-15L
Part No. 9999-95-PYT-16

GENERAL INFORMATION

00
SECTION

00-00

GENERAL INFORMATION 00-00

00-00 GENERAL INFORMATION

HOW TO USE THIS MANUAL	00-00-1
Range of Topics	00-00-1
Service Procedure	00-00-1
Symbols	00-00-2
Advisory Messages	00-00-3
UNITS	00-00-3
Conversion From SI Units (Système International d'Unités)	00-00-4
Number Of Digits For Converted Values	00-00-4
Converted Value Rounding Off And Rounding Up/down	00-00-4
ABBREVIATIONS	00-00-4
FUNDAMENTAL PROCEDURES	00-00-5

Preparation of Tools and Measuring Equipment	00-00-5
Special Service Tools	00-00-5
Disassembly	00-00-5
Inspection During Removal, Disassembly	00-00-5
Arrangement of Parts	00-00-6
Cleaning of Parts	00-00-6
Reassembly	00-00-6
Adjustment	00-00-7
Rubber Parts and Tubing	00-00-7
Torque Formulas	00-00-7
Vise	00-00-7

GENERAL INFORMATION

HOW TO USE THIS MANUAL

id000000000100

Range of Topics

- This manual contains procedures for performing all required service operations. The procedures are divided into the following basic operations:
 - Removal/Installation
 - Disassembly/Assembly
 - Replacement
 - Inspection
 - Adjustment
- Simple operations which can be performed easily just by looking at the actual unit (i.e., removal/installation of parts, cleaning of parts, and visual inspection) have been omitted.

Service Procedure

Inspection, adjustment

- Inspection and adjustment procedures are divided into steps. Important points regarding the location and contents of the procedures are explained in detail and shown in the illustrations.

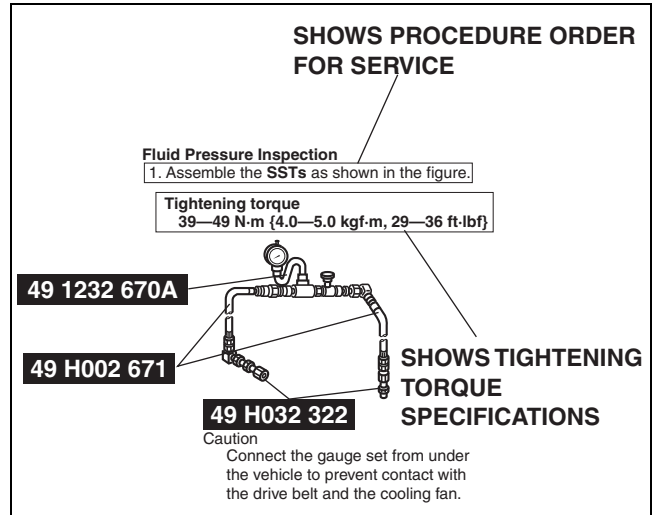

bpe2ue00000101

GENERAL INFORMATION

00-00

Repair procedure

1. Most repair operations begin with an overview illustration. It identifies the components, shows how the parts fit together, and describes visual part inspection. However, only removal/installation procedures that need to be performed methodically have written instructions.
2. Expendable parts, tightening torques, and symbols for oil, grease, and sealant are shown in the overview illustration. In addition, symbols indicating parts requiring the use of special service tools or equivalent are also shown.
3. Procedure steps are numbered and the part that is the main point of that procedure is shown in the illustration with the corresponding number. Occasionally, there are important points or additional information concerning a procedure. Refer to this information when servicing the related part.

Procedure

↓

①

↑

②

↓

"Removal/Installation" Portion

"Inspection After Installation" Portion

INSTALL THE PARTS BY PERFORMING STEPS 1—3 IN REVERSE ORDER

SHOWS SERVICE ITEM (S)

INDICATES ANY RELEVANT REFERENCES WHICH NEED TO BE FOLLOWED DURING INSTALLATION

SHOWS SPECIAL SERVICE TOOL (SST) FOR SERVICE OPERATION

SHOWS APPLICATION POINTS OF GREASE, ETC.

SHOWS NON-REUSEABLE PARTS

SHOWS TIGHTENING TORQUE SPECIFICATIONS

SHOWS DETAILS

SHOWS TIGHTENING TORQUE UNITS

SHOWS THERE ARE REFERRAL NOTES FOR SERVICE

SHOWS REFERRAL NOTES FOR SERVICE

LOWER TRAILING LINK, UPPER TRAILING LINK REMOVAL/INSTALLATION

1. Jack up the rear of the vehicle and support it with safety stands.
2. Remove the undercover. (See 01-10-4 Undercover Removal)
3. Remove in the order indicated in the table.
4. Install in the reverse order of removal.
5. Inspect the rear wheel alignment and adjust it if necessary.

1	Split pin
2	Nut
3	Lower trailing link ball joint (See 02-14-5 Lower Trailing Link Ball Joint Removal Note)
4	Bolt
5	Lower trailing link
6	Dust boot (lower trailing link)

7	Split pin
8	Nut
9	Upper trailing link ball joint (See 02-14-5 Upper Trailing Link Ball Joint Removal Note)
10	Nut
11	Upper trailing link
12	Dust boot (upper trailing link)

Lower Trailing Link Ball Joint, Upper Trailing Link Ball Joint Removal Note

- Remove the ball joint using the SSTs.

SHOWS SPECIAL SERVICE TOOL (SST) NO.

49 T028 304 UPPER TRAILING LINK
49 T028 305 LOWER TRAILING LINK

49 T028 303









KNUCKLE

bpe2ue0000001

GENERAL INFORMATION

Symbols

- There are eight symbols indicating oil, grease, fluids, sealant, and the use of **SST** or equivalent. These symbols show application points or use of these materials during service.

Symbol	Meaning	Kind
	Apply oil	New appropriate engine oil or gear oil
	Apply brake fluid	New appropriate brake fluid
	Apply automatic transaxle/ transmission fluid	New appropriate automatic transaxle/ transmission fluid
	Apply grease	Appropriate grease
	Apply sealant	Appropriate sealant
	Apply petroleum jelly	Appropriate petroleum jelly
	Replace part	O-ring, gasket, etc.
	Use SST or equivalent	Appropriate tools

Advisory Messages

- You will find several **Warnings**, **Cautions**, **Notes**, **Specifications** and **Upper and Lower Limits** in this manual.

Warning

- A Warning indicates a situation in which serious injury or death could result if the warning is ignored.

Caution

- A Caution indicates a situation in which damage to the vehicle or parts could result if the caution is ignored.

Note

- A Note provides added information that will help you to complete a particular procedure.

Specification

- The values indicate the allowable range when performing inspections or adjustments.

Upper and lower limits

- The values indicate the upper and lower limits that must not be exceeded when performing inspections or adjustments.

GENERAL INFORMATION

UNITS

id000000100400

Electric current	A (ampere)
Electric power	W (watt)
Electric resistance	ohm
Electric voltage	V (volt)
Length	mm (millimeter)
	in (inch)
Negative pressure	kPa (kilo pascal)
	mmHg (millimeters of mercury)
	inHg (inches of mercury)
Positive pressure	kPa (kilo pascal)
	kgf/cm ² (kilogram force per square centimeter)
	psi (pounds per square inch)
Number of revolutions	rpm (revolutions per minute)
Torque	N·m (Newton meter)
	kgf·m (kilogram force meter)
	kgf·cm (kilogram force centimeter)
	ft·lbf (foot pound force)
	in·lbf (inch pound force)
Volume	L (liter)
	US qt (U.S. quart)
	Imp qt (Imperial quart)
	ml (milliliter)
	cc (cubic centimeter)
	cu in (cubic inch)
	fl oz (fluid ounce)
Weight	g (gram)
	oz (ounce)

00-00

Conversion From SI Units (Système International d'Unités)

- All numerical values in this manual are based on SI units. Numbers shown in conventional units are converted from these values.

Number Of Digits For Converted Values

- The number digits for converted values is the same as the number of significant figures^{*1} of the SI unit.
- For the torque value, the number of significant figures is, in principle, is 2 digits, in consideration of market practicalities. However, if the number of decimal places at the upper and lower limits of the converted value differs, the one with least number of decimal places is used. In addition, if the integer part is 3 digits or more, the integer part becomes the significant number of figures.

*1 : The number of significant figures is the number of digits from the left-most non-zero digit to the right-most digit including 0. (Example: 0.12 is 2 digits, 41.0 is 3 digits)

Converted Value Rounding Off And Rounding Up/down

- If there is no tolerance in the SI unit value, after conversion, rounding off is to within the number of significant digits.
- If there is tolerance in the SI unit value and the figure after conversion indicates the upper limit, the number of digits is rounded down to within the number of significant figures. If it indicates the lower limit, they are rounded up to within the number of significant figures.
- Even if the SI unit value is the same, the converted value may differ based on whether that value is the upper or lower limit.

GENERAL INFORMATION

ABBREVIATIONS

id000000010100

ATX	Automatic Transaxle
EX	Exhaust
HLA	Hydraulic Lash Adjuster
IN	Intake

MTX	Manual Transaxle
OCV	Oil Control Valve
TDC	Top Dead Center
SST	Special Service Tool

FUNDAMENTAL PROCEDURES

id000000750100

Preparation of Tools and Measuring Equipment

- Be sure that all necessary tools and measuring equipment are available before starting any work.

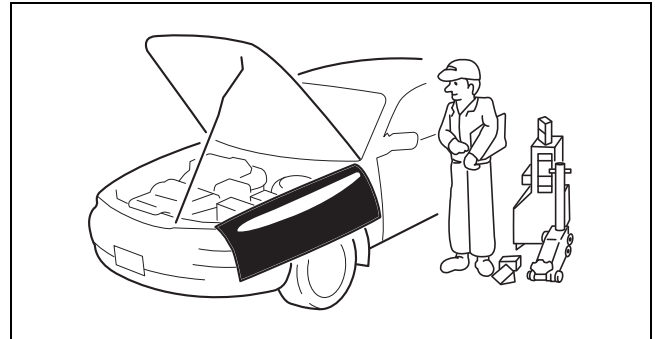

bpe2ue00000110

Special Service Tools

- Use special service tools or equivalent when they are required.

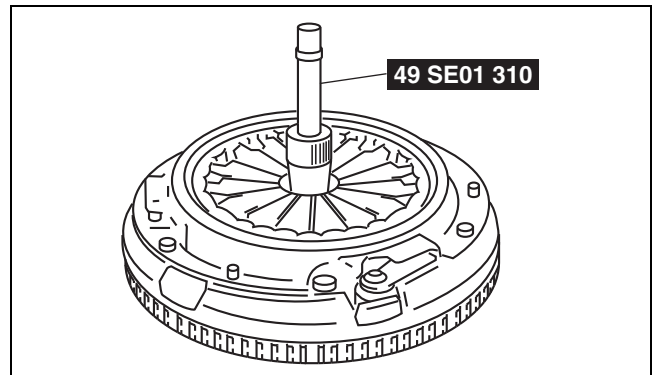

bpe2ue00000111

Disassembly

- If the disassembly procedure is complex, requiring many parts to be disassembled, all parts should be marked in a place that will not affect their performance or external appearance and identified so that reassembly can be performed easily and efficiently.

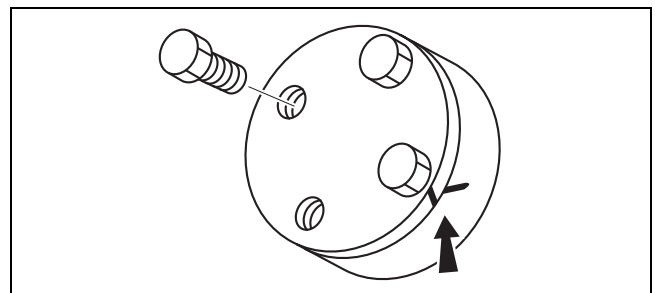

bpe2ue00000112

GENERAL INFORMATION

Inspection During Removal, Disassembly

- When removed, each part should be carefully inspected for malfunction, deformation, damage and other problems.

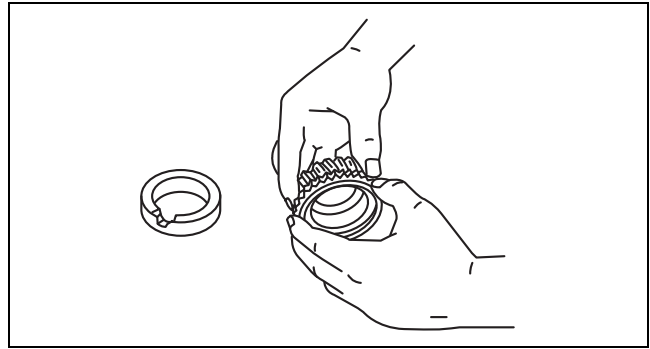

bpe2ue00000113

00-00

Arrangement of Parts

- All disassembled parts should be carefully arranged for reassembly.
- Be sure to separate or otherwise identify the parts to be replaced from those that will be reused.

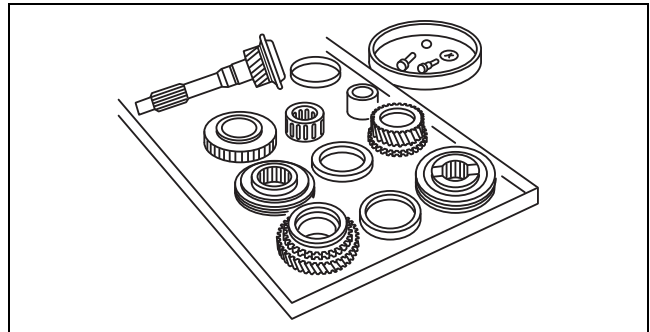

bpe2ue00000114

Cleaning of Parts

- All parts to be reused should be carefully and thoroughly cleaned in the appropriate method.

Warning

- **Using compressed air can cause dirt and other particles to fly out causing injury to the eyes. Wear protective eye wear whenever using compressed air.**

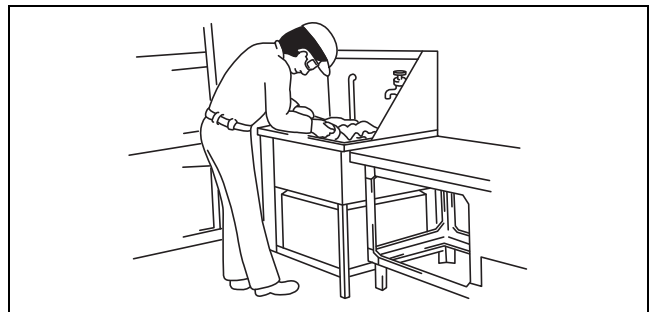

bpe2ue00000002

Reassembly

- Standard values, such as torques and certain adjustments, must be strictly observed in the reassembly of all parts.
- If removed, the following parts should be replaced with new ones:
 - Oil seals
 - Gaskets
 - O-rings
 - Lockwashers
 - Cotter pins
 - Nylon nuts

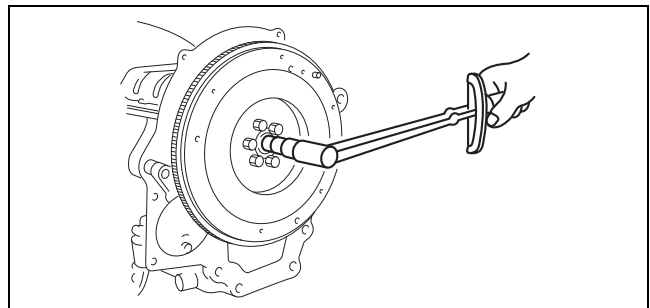

bpe2ue00000115

GENERAL INFORMATION

- Depending on location:
 - Sealant and gaskets, or both, should be applied to specified locations. When sealant is applied, parts should be installed before sealant hardens to prevent leakage.
 - Oil should be applied to the moving components of parts.
 - Specified oil or grease should be applied at the prescribed locations (such as oil seals) before reassembly.

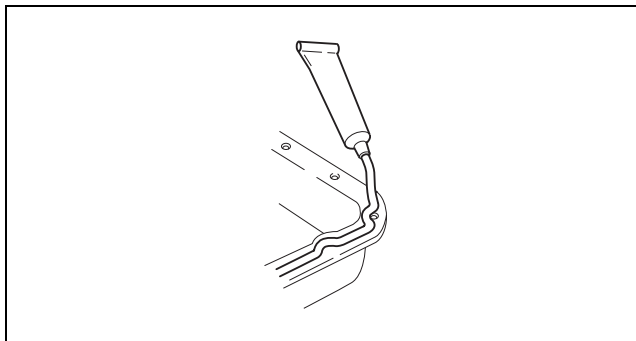

bpe2ue00000116

Adjustment

- Use suitable gauges and testers when making adjustments.

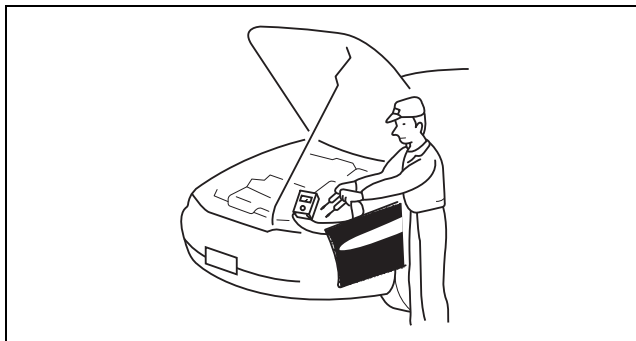

bpe2ue00000117

Rubber Parts and Tubing

- Prevent gasoline or oil from getting on rubber parts or tubing.

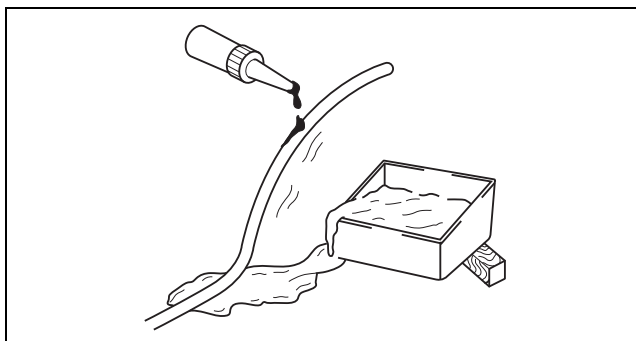

bpe2ue00000118

Torque Formulas

- When using a torque wrench-**SST** or equivalent combination, the written torque must be recalculated due to the extra length that the **SST** or equivalent adds to the torque wrench. Recalculate the torque by using the following formulas. Choose the formula that applies to you.

Torque Unit	Formula
N·m	$N \cdot m \times [L / (L + A)]$
kgf·m	$kgf \cdot m \times [L / (L + A)]$
kgf·cm	$kgf \cdot cm \times [L / (L + A)]$
ft·lbf	$ft \cdot lbf \times [L / (L + A)]$
in·lbf	$in \cdot lbf \times [L / (L + A)]$

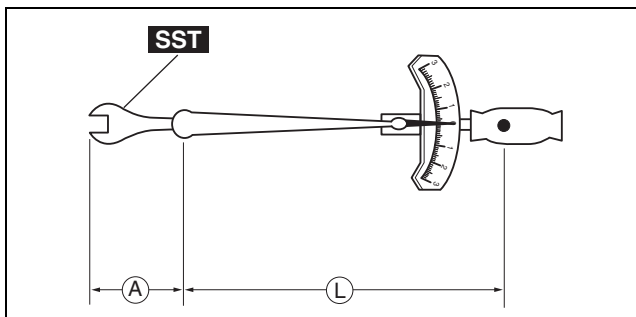

bpe2ue00000119

A : The length of the **SST** past the torque wrench drive.
 L : The length of the torque wrench.

GENERAL INFORMATION

Vise

- When using a vise, put protective plates in the jaws of the vise to prevent damage to parts.

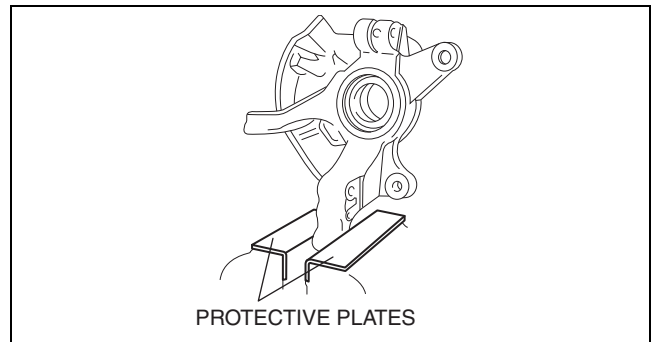

bpe2ue00000120

00-00

ENGINE

01 SECTION

01-10

MECHANICAL 01-10

TECHNICAL DATA 01-50

01-10 MECHANICAL

ELECTRIC VARIABLE VALVE TIMING	
MOTOR/DRIVER INSPECTION	01-10-2
HYDRAULIC VARIABLE VALVE TIMING	
ACTUATOR INSPECTION	01-10-2
ELECTRIC VARIABLE VALVE TIMING	
ACTUATOR INSPECTION	01-10-2
OIL CONTROL VALVE	
(OCV) INSPECTION	01-10-3
Coil Resistance Inspection	01-10-3
Spool Valve Operation Inspection	01-10-3
HYDRAULIC LASH ADJUSTER	
(HLA) INSPECTION	01-10-4
ROCKER ARM INSPECTION	01-10-4
ENGINE OVERHAUL	
SERVICE WARNING	01-10-4
ENGINE	
MOUNTING/DISMOUNTING	01-10-5
Mounting	01-10-5
Dismounting	01-10-6
TIMING CHAIN DISASSEMBLY	01-10-6
Crankshaft Pulley Lock	
Bolt Disassembly Note	01-10-9
Oil Pan Disassembly Note	01-10-9
Engine Front Cover	
Disassembly Note	01-10-9
Front Oil Seal Disassembly Note	01-10-10
Chain Tensioner Disassembly Note	01-10-10
Oil Pump Chain Disassembly Note	01-10-13
CYLINDER HEAD	
DISASSEMBLY (I)	01-10-15
Electric Variable Valve Timing Actuator, Hydraulic Variable Valve Timing	
Actuator Disassembly Note	01-10-17
Camshaft Cap Disassembly Note	01-10-17
Rocker Arm Disassembly Note	01-10-17
HLA Disassembly Note	01-10-17
Cylinder Head Disassembly Note	01-10-18
CYLINDER HEAD	
DISASSEMBLY (II)	01-10-18
Valve Keeper Disassembly Note	01-10-20
Valve Seal Disassembly Note	01-10-20
CYLINDER BLOCK	
DISASSEMBLY (I)	01-10-21
Drive Plate Installation Bolt	
Disassembly Note	01-10-22
Rear Oil Seal Disassembly Note	01-10-22
CYLINDER BLOCK	
DISASSEMBLY (II)	01-10-22

Connecting Rod Cap	
Disassembly Note	01-10-24
Connecting Rod Bearing	
Disassembly Note	01-10-24
Piston, Connecting Rod	
Disassembly Note	01-10-24
Snap Ring Disassembly Note	01-10-24
Lower Cylinder Block	
Disassembly Note	01-10-24
Thrust Bearing And Main Bearing	
Disassembly Note	01-10-25
Crankshaft Disassembly Note	01-10-25
CYLINDER HEAD INSPECTION	01-10-26
VALVE SEAT INSPECTION/REPAIR	01-10-26
VALVE, VALVE	
GUIDE INSPECTION	01-10-27
VALVE GUIDE REPLACEMENT	01-10-29
Removal	01-10-29
Installation	01-10-29
VALVE SPRING INSPECTION	01-10-29
CAMSHAFT INSPECTION	01-10-30
CYLINDER BLOCK INSPECTION	01-10-32
OIL JET VALVE INSPECTION	01-10-32
PISTON INSPECTION	01-10-32
PISTON RING INSPECTION	01-10-33
PISTON PIN INSPECTION	01-10-34
PISTON AND CONNECTING	
ROD INSPECTION	01-10-35
CONNECTING ROD INSPECTION	01-10-35
CONNECTING ROD	
CLEARANCE INSPECTION	01-10-35
CRANKSHAFT INSPECTION	01-10-36
BOLT INSPECTION	01-10-38
CYLINDER BLOCK ASSEMBLY (I)	01-10-38
Thrust Bearing And Main Bearing	
Assembly Note	01-10-40
Plate Assembly Note	01-10-41
Lower Cylinder Block	
Assembly Note	01-10-41
Piston Pin Assembly Note	01-10-43
Snap Ring Assembly Note	01-10-43
Piston Ring Assembly Note	01-10-43
Connecting Rod Bearing	
Assembly Note	01-10-44
Piston, Connecting	
Rod Assembly Note	01-10-45
Connecting Rod Cap	
Assembly Note	01-10-45
CYLINDER BLOCK ASSEMBLY (II)	01-10-46

MECHANICAL

Balancer Unit Assembly Note	01-10-47	Electric Variable Valve Timing Actuator, Hydraulic Variable Valve Timing Actuator Assembly Note.	01-10-62
Oil Pump Assembly Note	01-10-48	TIMING CHAIN ASSEMBLY	01-10-62
Rear Oil Seal Assembly Note	01-10-49	Oil Pump Chain Assembly Note.	01-10-66
End Plate Assembly Note	01-10-51	Timing Chain Assembly Note.	01-10-68
Drive Plate Installation Bolt Assembly Note.	01-10-51	Engine Front Cover Assembly Note	01-10-70
CYLINDER HEAD ASSEMBLY (I)	01-10-51	Oil Pan Assembly Note	01-10-74
Valve Seal Assembly Note	01-10-53	Front Oil Seal Assembly Note	01-10-76
Valve Spring Assembly Note.	01-10-53	Crankshaft Pulley Lock Bolt Assembly Note	01-10-77
Valve Keeper Assembly Note	01-10-54	Oil Shower Pipe Assembly Note	01-10-77
Blind cover Assembly Note	01-10-54	Cylinder Head Cover Assembly Note	01-10-77
CYLINDER HEAD ASSEMBLY (II).	01-10-54		
Cylinder Head Assembly Note	01-10-57		
HLA Assembly Note	01-10-57		
Rocker Arm Assembly Note	01-10-59		
Camshaft Assembly Note	01-10-59		

ELECTRIC VARIABLE VALVE TIMING MOTOR/DRIVER INSPECTION

id011000828100

Caution

- Do not disassemble the electric variable valve timing motor/driver because it is a precision unit.
- Do not apply excessive force when rotating the electric variable valve timing motor joint. If it is rotated with excessive force, the electric variable valve timing motor could be damaged.

1. Rotate the electric variable valve timing motor joint to the left and right by your fingers and verify that it rotates smoothly in 15° increments.

Note

- Rotate the joint area smoothly using only the tips of your fingers.
- The electric variable valve timing motor joint moves in 15° increments, and if the joint is moved 24 times, it rotates one full rotation.
- If it does not rotate smoothly, replace the electric variable valve timing motor/driver.

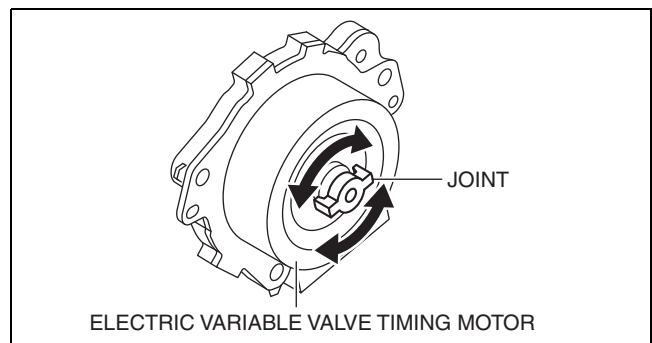

am3uuw0000904

HYDRAULIC VARIABLE VALVE TIMING ACTUATOR INSPECTION

id011000126800

Caution

- Do not disassemble the hydraulic variable valve timing actuator because it is a precision unit.

1. Verify that the notch of the holder and notch of the cover on the hydraulic variable valve timing actuator are aligned and fitted.

- If the notch and notch are not aligned, rotate the holder (camshaft installation) until a click is heard and verify that they are aligned and fixed in place.
 - If the notch and notch are not aligned or the holder and cover are not secured even if their notch and notch are aligned, replace the hydraulic variable valve timing actuator.

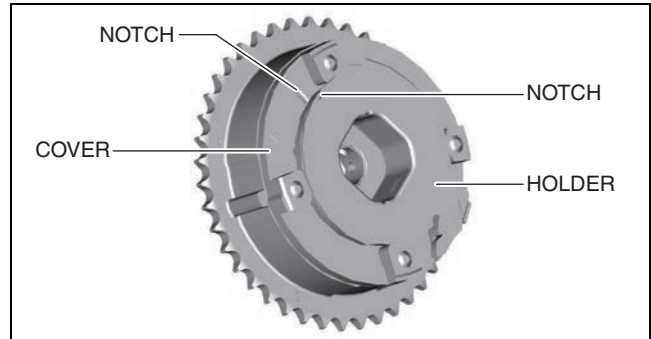

bp25ue0000083

01-10

ELECTRIC VARIABLE VALVE TIMING ACTUATOR INSPECTION

id011000555500

Caution

- Do not disassemble the electric variable valve timing actuator because it is a precision unit.

1. Rotate the eccentric shaft of the electric variable valve timing actuator to the left and right by hand and verify that it rotates smoothly.

- If it does not rotate smoothly, replace the electric variable valve timing actuator.

Note

- Hook a finger onto the joint groove of the eccentric shaft to rotate the shaft easily.
- The eccentric shaft stops rotating at the maximum retard position when it is rotated counterclockwise as viewed from the front, and at the maximum advance position when rotated clockwise.

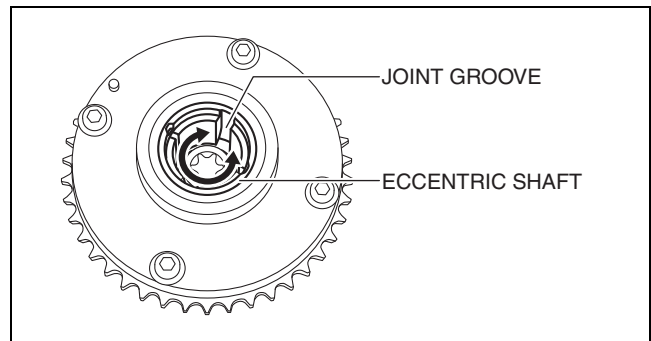

bpe2ue0000097

OIL CONTROL VALVE (OCV) INSPECTION

id011000801400

Coil Resistance Inspection

1. Measure the resistance between terminals A and B using an ohmmeter.

OCV coil resistance

6.9—7.5 ohms [20°C {68°F}]

- If it is not within the specification, replace the OCV.

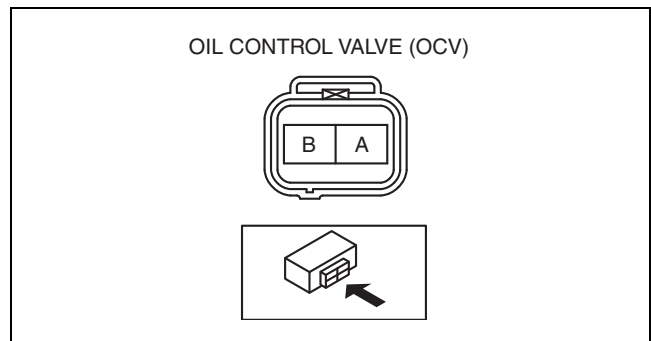

bpe5ue0000015

MECHANICAL

Spool Valve Operation Inspection

1. Verify that the spool valve in the OCV is in the maximum valve timing advance position as indicated in the figure.
 - If there is any malfunction, replace the OCV.

Note

- When applying battery positive voltage between the OCV terminals, the connection can be either of the following:
 - Positive battery cable to terminal A, negative battery cable to terminal B
 - Positive battery cable to terminal B, negative battery cable to terminal A

2. Apply battery positive voltage between the OCV terminals and verify that the spool valve operates and moves to the maximum valve timing retard position.

- If there is any malfunction, replace the OCV.

3. Stop applying battery positive voltage and verify that the spool valve returns to the maximum valve timing advance position.

- If there is any malfunction, replace the OCV.

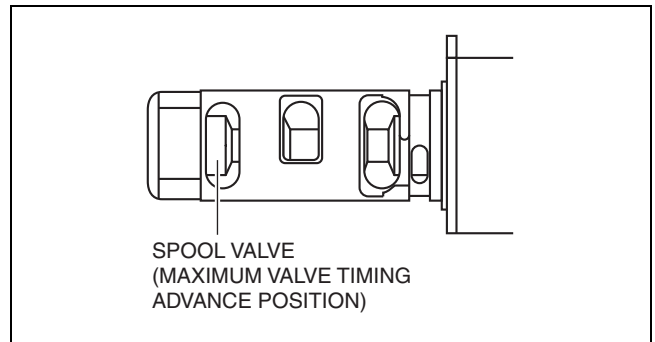

bpe1ze00000100

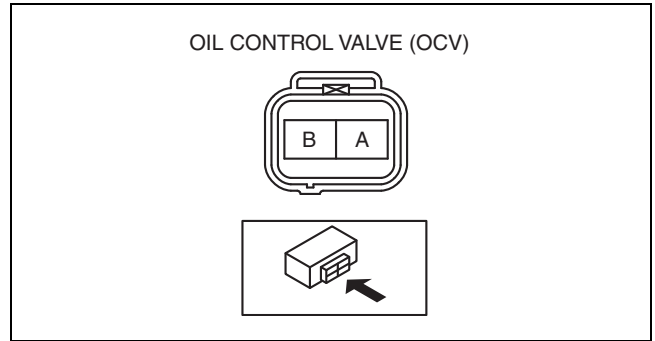

bpe5ue00000015

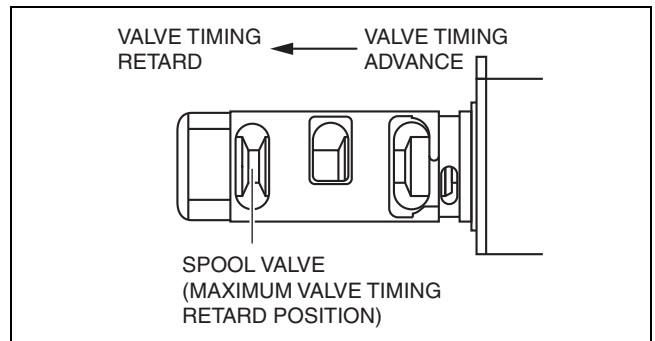

bpe1ze00000101

id011000805000

HYDRAULIC LASH ADJUSTER (HLA) INSPECTION

1. Visually inspect the HLA surface where it contacts the rocker arm.
 - If there is any malfunction, replace the HLA.

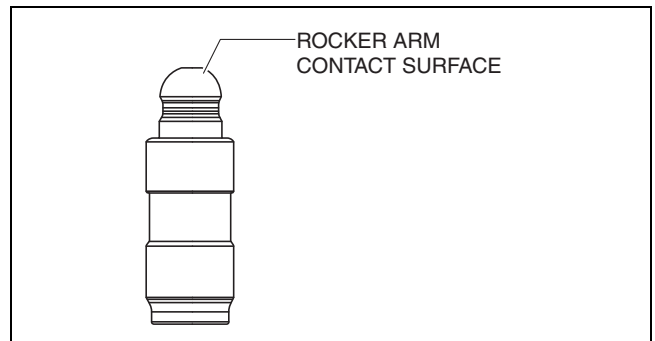

am3uuw0000898

MECHANICAL

ROCKER ARM INSPECTION

id011000904800

1. Rotate the roller or the rocker arm by hand and verify that rotates smoothly.
 - If it does not rotate smoothly, replace the rocker arm.
2. Visually inspect the rocker arm surface where it contacts the HLA and valve stem.
 - If there is any malfunction, replace the rocker arm.

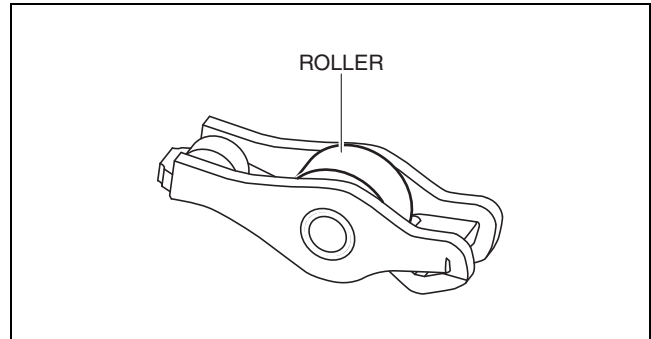

bpe2ue00000096

01-10

ENGINE OVERHAUL SERVICE WARNING

id011000503900

Warning

- **Continuous exposure to USED engine oil has been shown to cause skin cancer in laboratory mice. Protect your skin by washing with soap and water immediately after performing work.**

ENGINE MOUNTING/DISMOUNTING

id011000507000

Special Service Tool (SST)

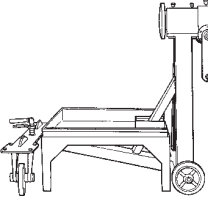
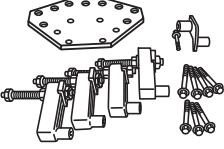
1. : Mazda SST number 2. : Global SST number		
1: 49 0107 680A 2: - Engine stand		1: 49 L010 1A0 2: - Engine hanger set 

Mounting

1. Install the **SST** (arms) to the three positions as shown in the figure and temporarily tighten the bolts (Part No. **9YA20-1003** or **M10 × 1.5** length **90 mm {3.55 in}**).

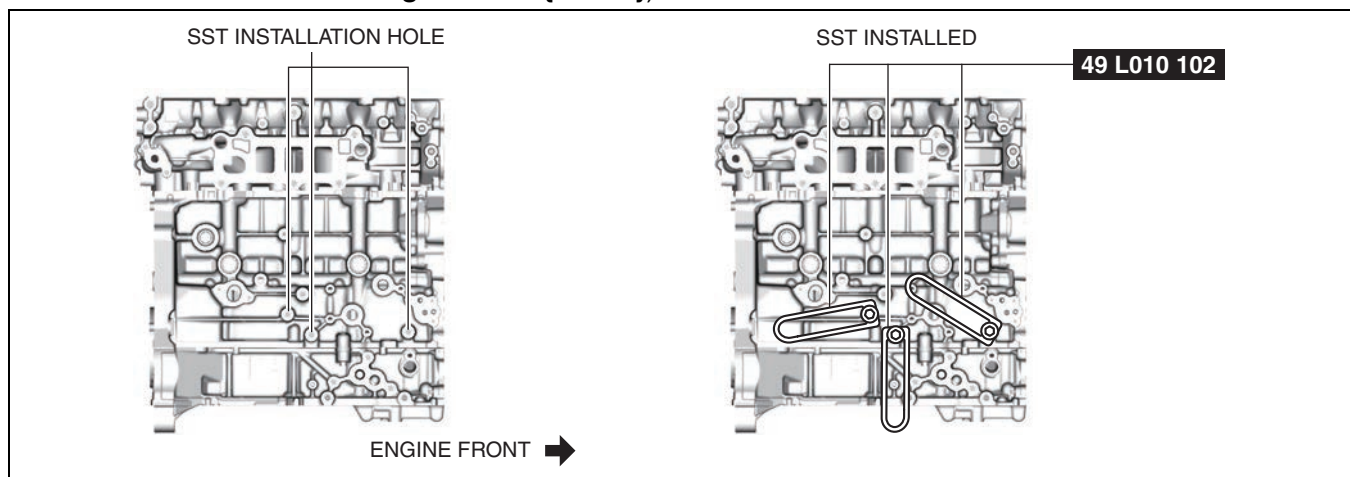

bp25ue00000076

MECHANICAL

2. Install the **SSTs** (bolts and nuts) to the three positions of the **SST** (plate) as shown in the figure.

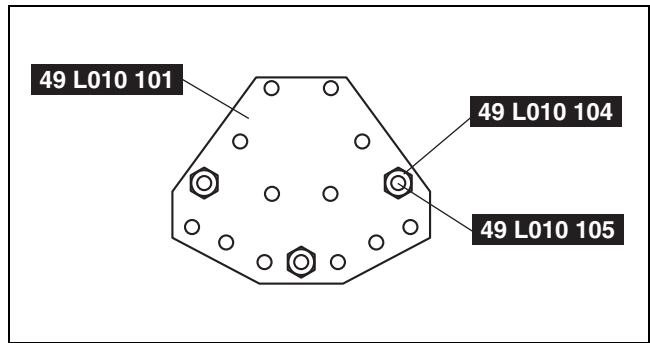

bp31je00000140

3. Install the **SST** (bolts, nuts and plate) set in Step 2 to the **SST** (arms) set in Step 1 using the **SSTs** (hook and nuts).
4. Adjust the bolts so that **approx. 20 mm {0.79 in}** of thread is exposed from the side of the plate.
5. Adjust the bolts and nuts so that the plate and arms are parallel.
6. Tighten the **SSTs** (bolts and nuts) to affix the **SST** firmly.
7. Install the engine to the **SST** (engine stand).
8. Remove the oil drain plug and drain the engine oil.
9. Replace the gasket with a new one and install the oil pan drain plug.

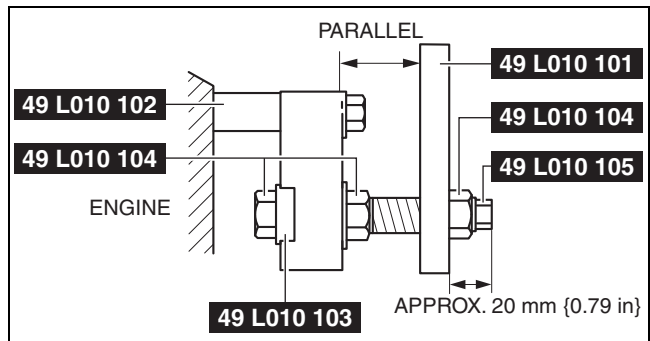

bpe2ue00000089

Tightening torque

30—41 N·m {3.1—4.1 kgf·m, 23—30 ft·lbf}

Dismounting

1. Dismount in the reverse order of mounting.

TIMING CHAIN DISASSEMBLY

id011000505500

Special Service Tool (SST)

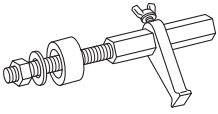
1. : Mazda SST number	
2. : Global SST number	
1: 49 E011 1A0	
2: -	
Ring gear brake set	

01-10

Caution

- If the camshaft is rotated with the timing chain removed and the piston at the top dead center position, the valve may contact the piston and the engine could be damaged. When rotating the camshaft with the timing chain removed, rotate it after lowering the piston from the top dead center position.
- When rotating the camshaft using a wrench on the cast hexagon, the wrench may contact the rocker arm and damage the rocker arm. To prevent damage to the rocker arm when holding the camshaft on the cast hexagon, use a wrench on the rear side of the engine as shown in the figure to secure a clearance between the cam.

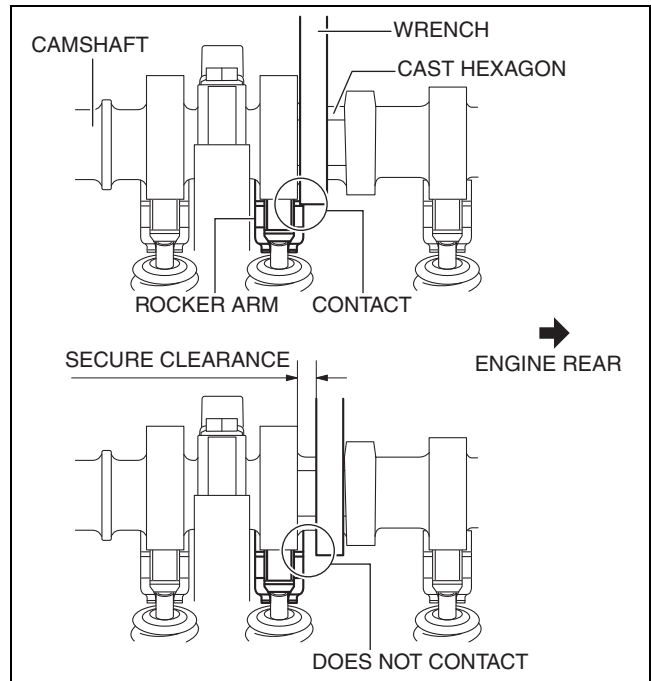

am3uuw0000883

Note

- Width at the cast hexagon of the camshaft is 22—24 mm {0.87—0.94 in}.

1. Disassemble in the order indicated in the table.

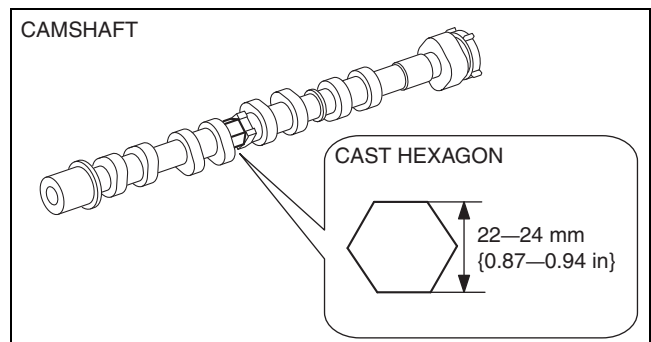

am3uuw0000902

MECHANICAL

U.S.A. and CANADA

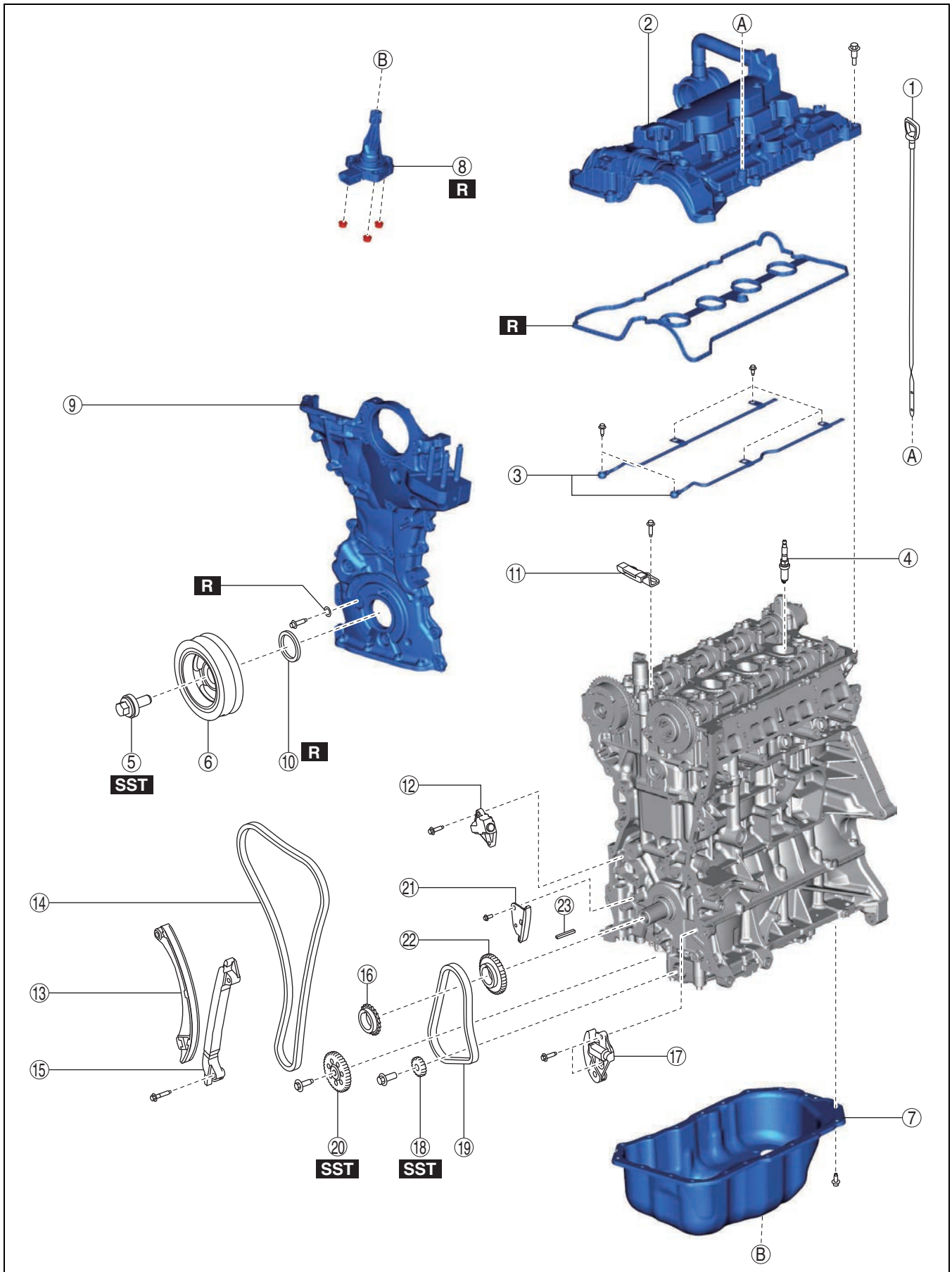

bp25ue0000045

MECHANICAL

Except U.S.A. and CANADA

01-10

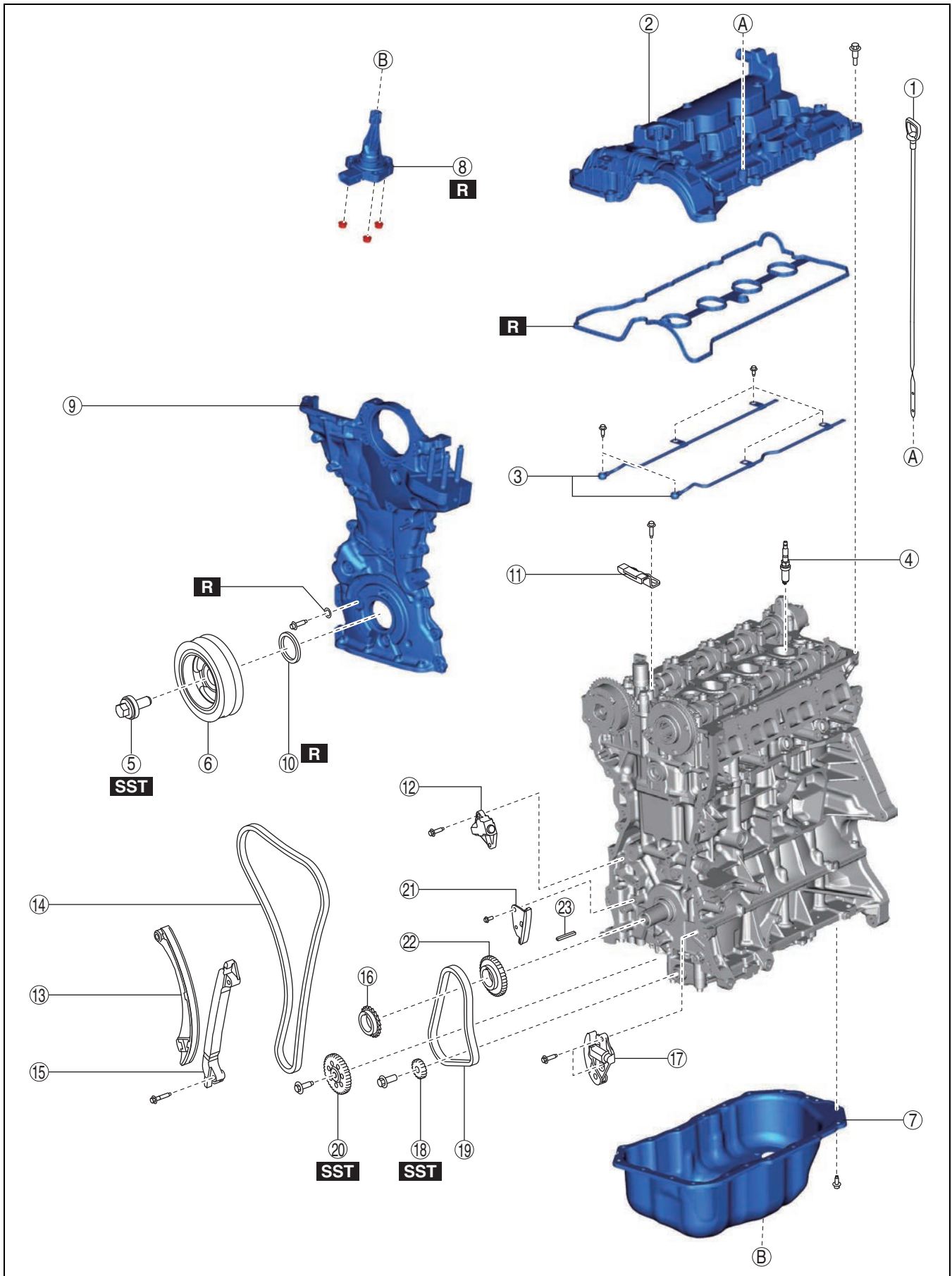

bp25ue0000046

MECHANICAL

1	Dipstick
2	Cylinder head cover
3	Oil shower pipe
4	Spark plug
5	Crankshaft pulley lock bolt (See 01-10-9 Crankshaft Pulley Lock Bolt Disassembly Note.)
6	Crankshaft pulley
7	Oil pan (See 01-10-9 Oil Pan Disassembly Note.)
8	Oil level sensor
9	Engine front cover (See 01-10-9 Engine Front Cover Disassembly Note.)
10	Front oil seal (See 01-10-10 Front Oil Seal Disassembly Note.)
11	Chain guide (No.1)

12	Chain tensioner (See 01-10-10 Chain Tensioner Disassembly Note.)
13	Tensioner arm
14	Timing chain
15	Chain guide (No.2)
16	Crankshaft sprocket
17	Oil pump chain tensioner (See 01-10-13 Oil Pump Chain Disassembly Note.)
18	Balancer shaft sprocket (See 01-10-13 Oil Pump Chain Disassembly Note.)
19	Oil pump chain (See 01-10-13 Oil Pump Chain Disassembly Note.)
20	Oil pump driven sprocket (See 01-10-13 Oil Pump Chain Disassembly Note.)
21	Oil pump chain guide
22	Oil pump drive sprocket
23	Key

Crankshaft Pulley Lock Bolt Disassembly Note

1. Hold the crankshaft using the **SST**.
2. Remove the crankshaft pulley lock bolt.

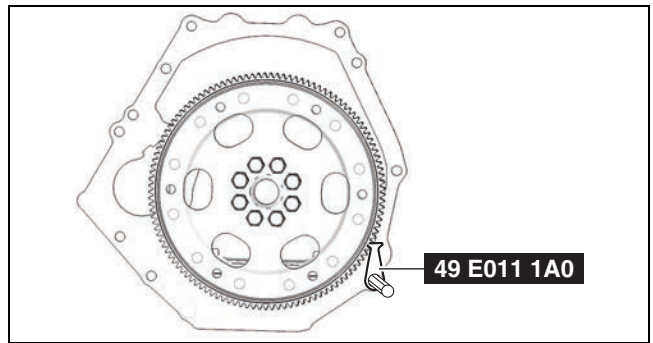

bp25ue0000093

Oil Pan Disassembly Note

1. Remove the oil pan using a separator tool.

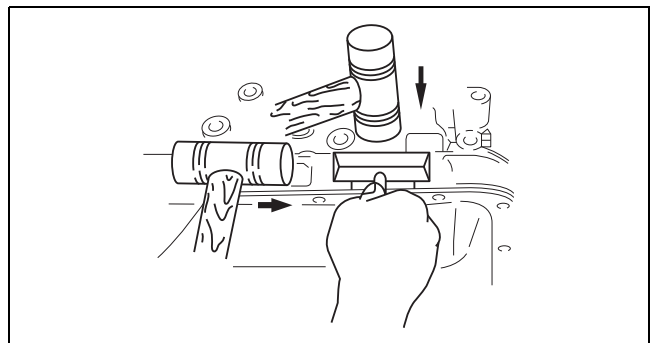

adejjw00003946

Engine Front Cover Disassembly Note

1. Remove the engine front cover installation bolts.
2. Using a screwdriver wrapped in a cloth, peel the sealant away a little at a time, and remove the engine front cover.

Caution

- Do not apply excessive force to the screwdriver. Otherwise, the engine front cover could be damaged.
- Be careful not to scratch or damage the seal surface. Otherwise, it could cause oil leakage.

01-10

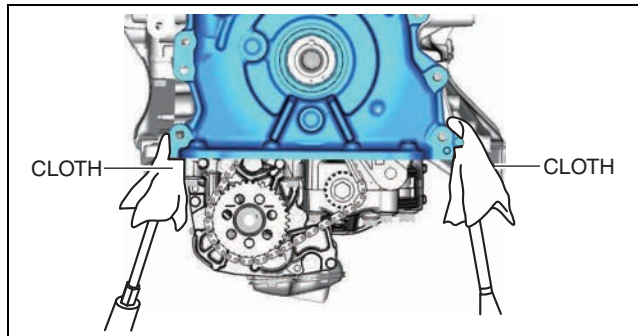

bp25ue0000048

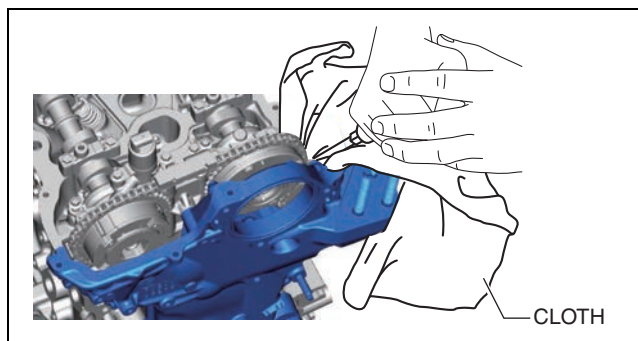

bp25ue0000049

Front Oil Seal Disassembly Note

1. Remove the oil seal using a flathead screwdriver with the tip protected by a clean cloth.

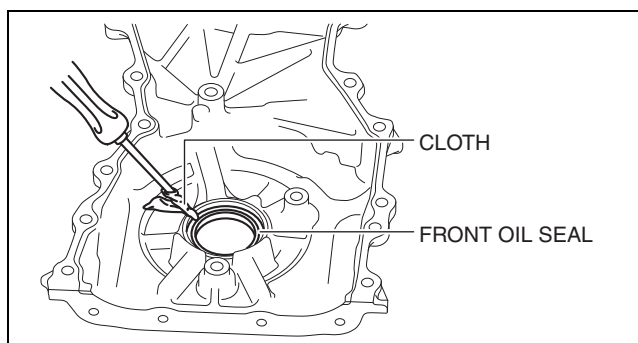

bpe2ue00000100

Chain Tensioner Disassembly Note

1. Verify the chain tensioner shape and identify the chain tensioner type.

Note

- Verifying the chain tensioner type is necessary because the following procedures may differ according to the type of tensioner.

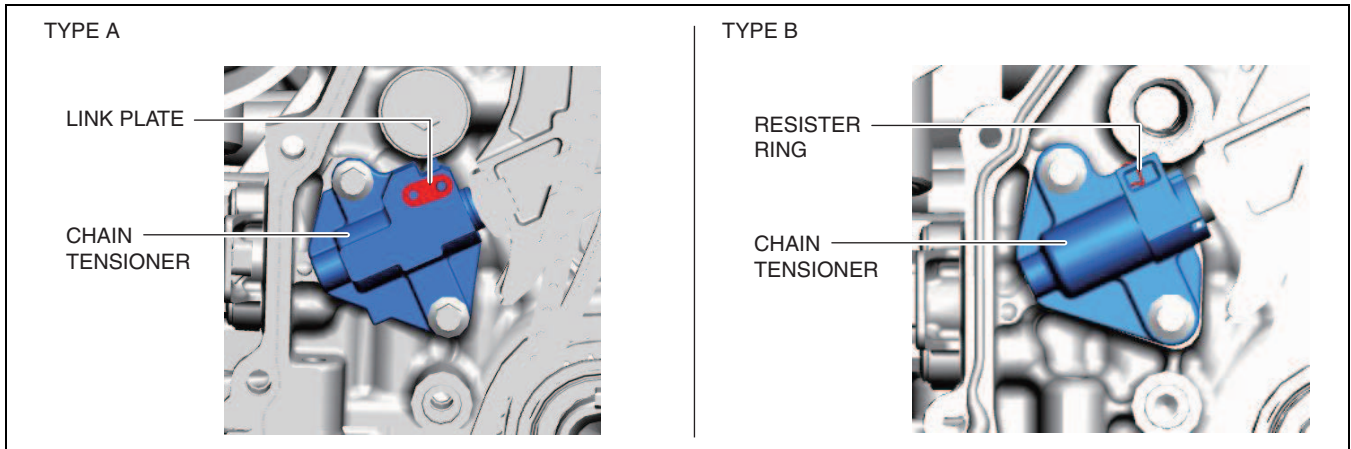

ac4ccw00002689

2. While moving the exhaust camshaft back and forth in the direction of the arrow using a wrench on the cast hexagon, press down the link plate of the timing chain tensioner using a precision screwdriver and release the plunger lock. (Chain tensioner type A)

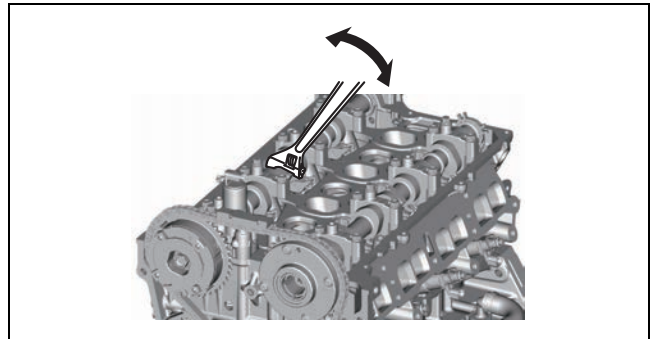

bp25ue00000050

Note

- When moving the exhaust camshaft back and forth, the timing chain pushes the plunger in the chain tensioner making it easier to operate the link plate.

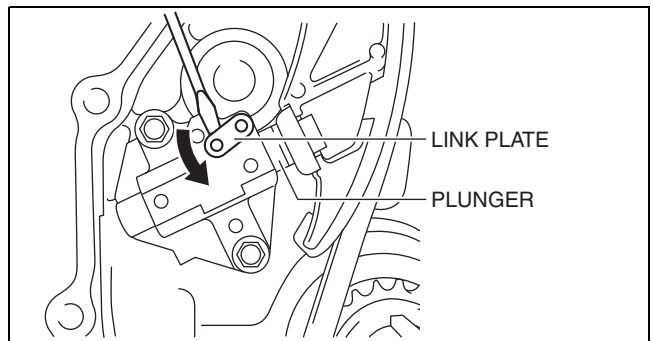

am3uuw0000885

3. Push back the plunger slowly in the direction shown in the figure with the link plate still pushed down. (Chain tensioner type A)
4. Remove the screwdriver from the link plate with the plunger still pushed down. (Chain tensioner type A)
5. Release the force slightly from the plunger, and move it back and forth 2—3 mm {0.08—0.11 in}. (Chain tensioner type A)

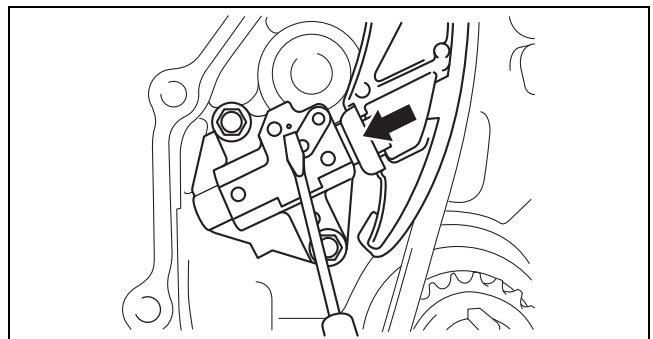

am3uuw0000885

MECHANICAL

6. Insert a wire with an **approx. diameter of 1.5 mm {0.059 in}** or a paper clip where the link plate hole and the tensioner body hole overlap to secure the link plate and lock the plunger. (Chain tensioner type A)

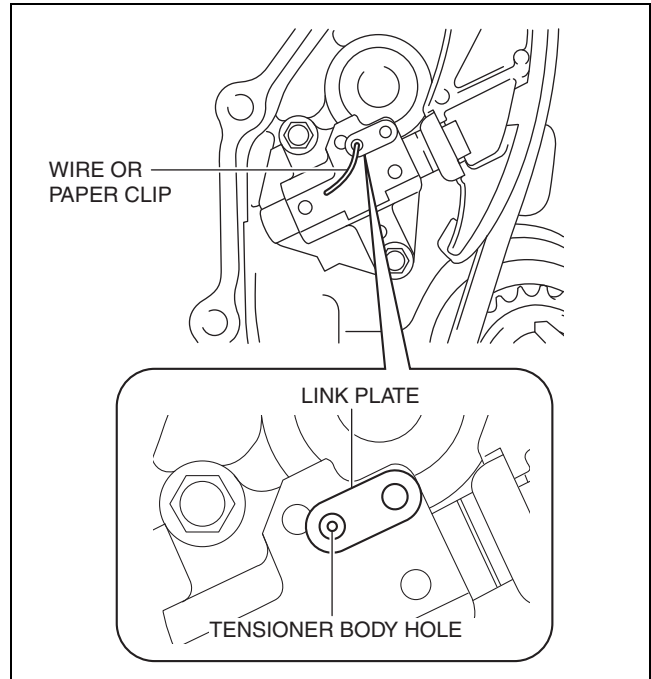

am3uuw0000885

01-10

7. Loosen the chain tensioner using the following procedure: (Chain tensioner type B)

- (1) Insert a metal rod (diameter **approx. 1.4 mm {0.055 in}**, length **approx. 55 mm {2.2 in}**) into the hole in the body of the chain tensioner.

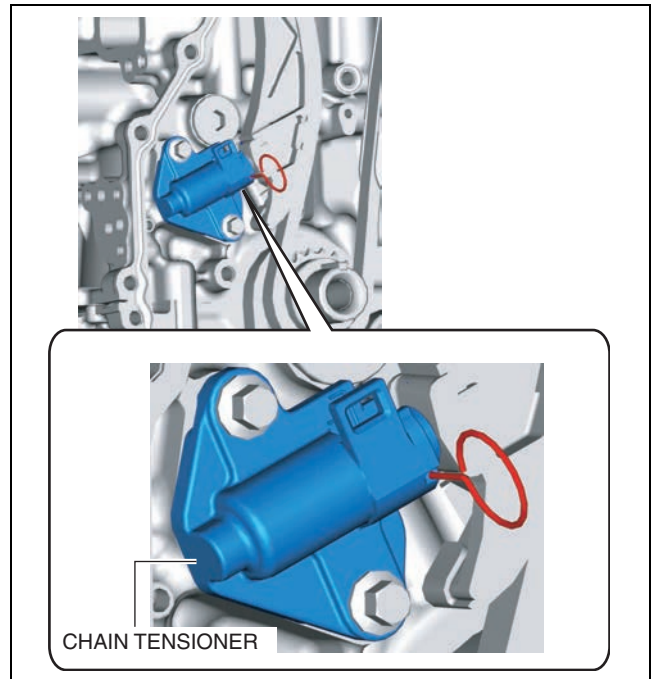

amxzzw0000302

- (2) Press the resister ring and unlock the plunger.

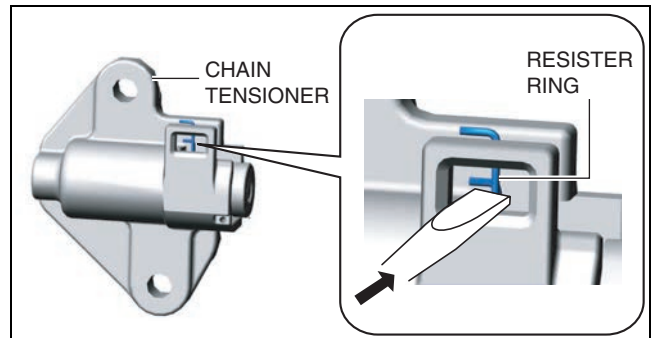

amxzzw0000302

MECHANICAL

- (3) Press the timing chain in the direction of the arrow and press in the chain tensioner plunger to the position where the groove and body hole are aligned.

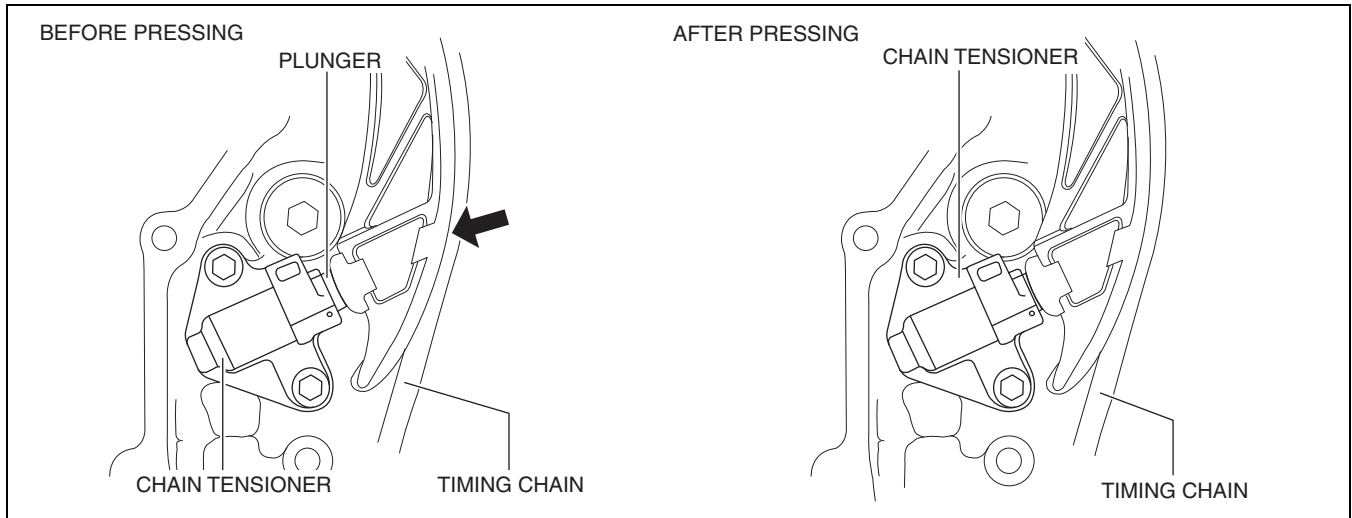

amxuuw0000440

- (4) With the plunger pressed in, further insert the metal rod set in (1) above.

Note

- The rod secures the plunger and releases the tension.

- (5) Loosen the power of the hand pressing the plunger and verify that the pressed-in rod does not move.

8. Remove the chain tensioner.

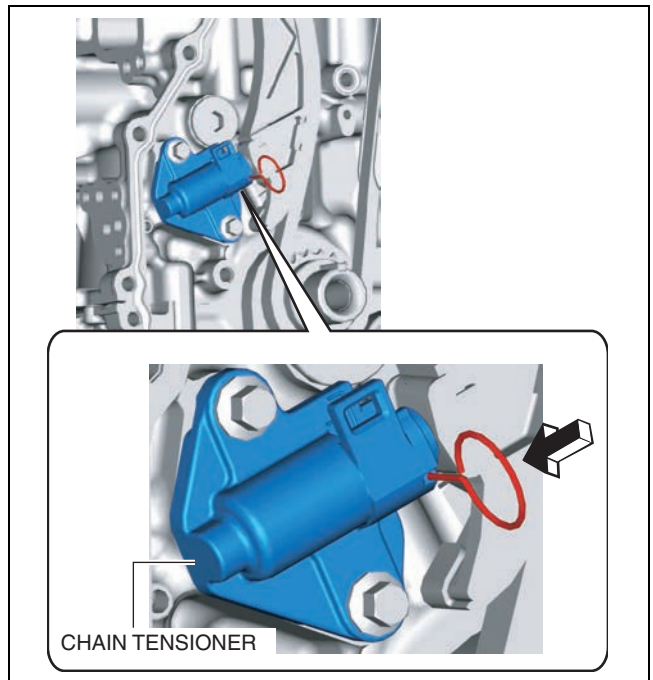

amxzzw0000302

Oil Pump Chain Disassembly Note

1. Hold the crankshaft using the **SST**.
2. Slightly loosen the balancer shaft sprocket and oil pump driven sprocket installation bolts.

Note

- At this stage, only loosen the installation bolts, do not remove them. Remove the bolts after removing the oil pump chain tensioner.

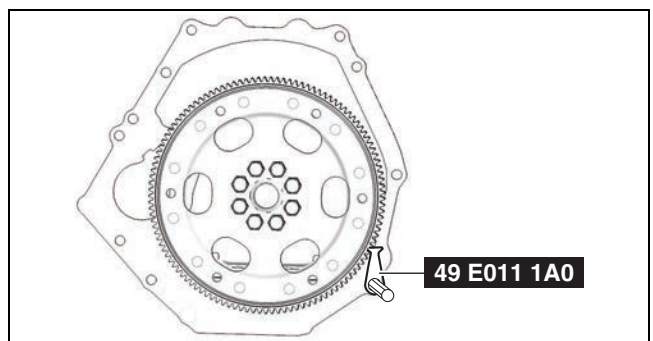

bp25ue0000093

MECHANICAL

3. Set a cloth wrapped flathead screwdriver in the gap between the oil pump drive sprocket and the oil pump chain as shown in the figure.

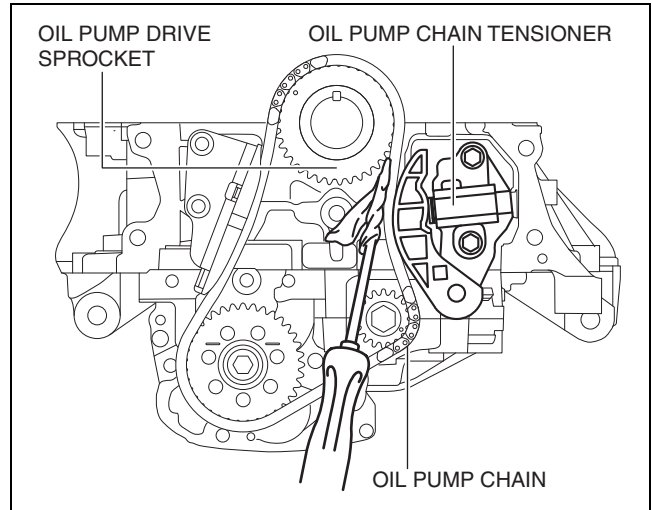

bp25ue0000051

01-10

4. Move the screwdriver in the direction of the arrow and press the oil pump chain, and then press on the plunger of the oil pump chain tensioner.

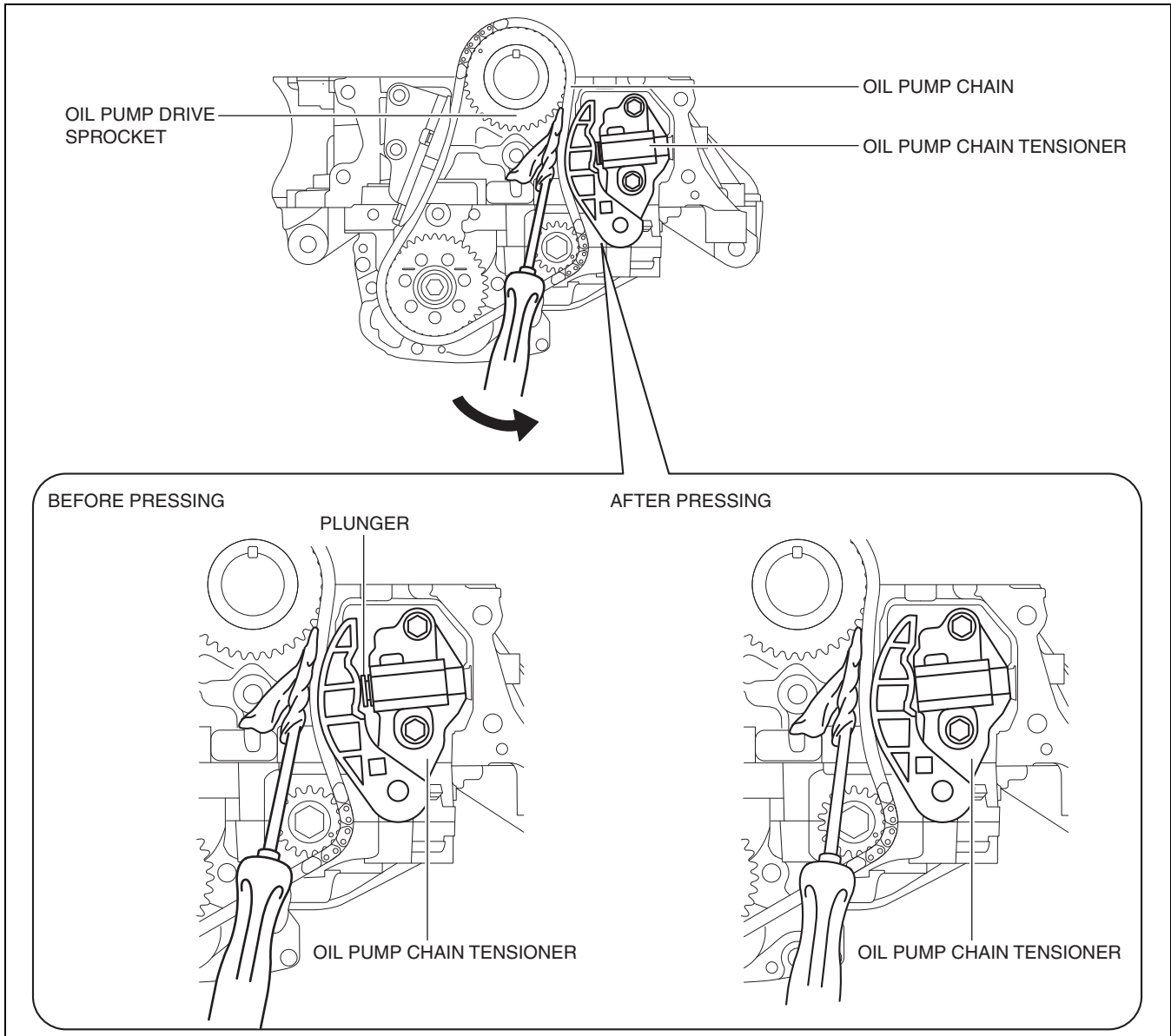

bp25ue0000052

MECHANICAL

5. Insert a wire with an approx. diameter of 1.4 mm {0.055 in} or a paper clip into the body hole of the oil pump chain tensioner with the plunger pressed.

Note

- The wire or paper clip secures the plunger, and the tension can be released.

6. Remove the oil pump chain tensioner.
7. Remove the oil pump chain and balancer shaft sprocket as a single unit.
8. Remove the oil pump driven sprocket.

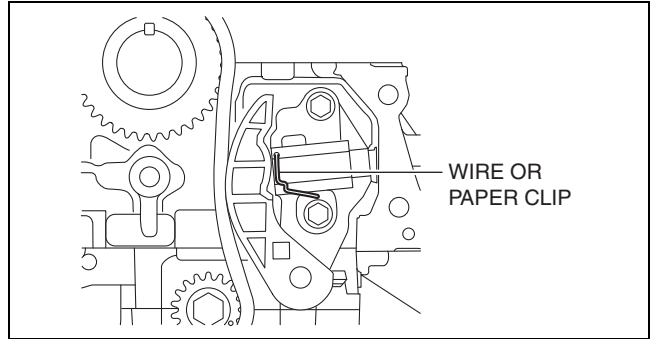

bp25ue0000053

CYLINDER HEAD DISASSEMBLY (I)

id011000500400

Caution

- If the camshaft is rotated with the timing chain removed and the piston at the top dead center position, the valve may contact the piston and the engine could be damaged. When rotating the camshaft with the timing chain removed, rotate it after lowering the piston from the top dead center position.
- When rotating the camshaft using a wrench on the cast hexagon, the wrench may contact the rocker arm and damage the rocker arm. To prevent damage to the rocker arm when holding the camshaft on the cast hexagon, use a wrench on the rear side of the engine as shown in the figure to secure a clearance between the cam.
- Carefully assemble the HLA because the specification is different between the intake side and the exhaust side.

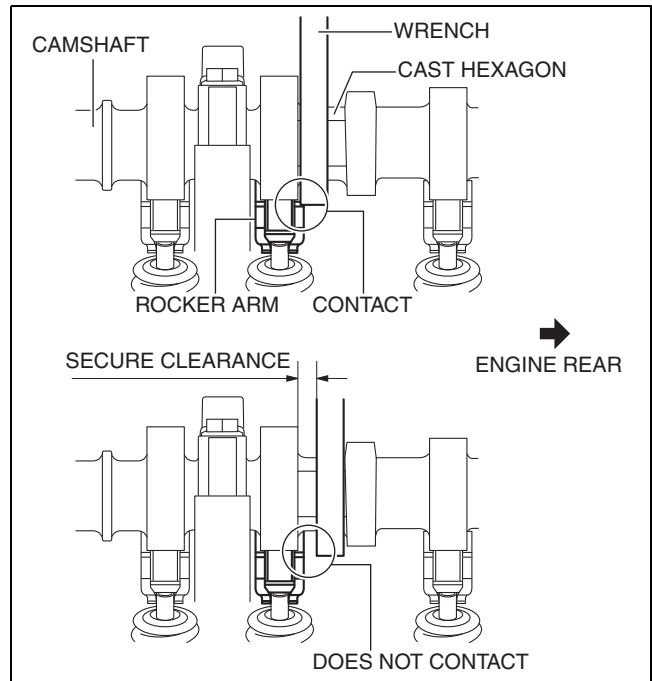

am3uuw0000883

Note

- Width at the cast hexagon of the camshaft is 22—24 mm {0.87—0.94 in}.

1. Disassemble in the order indicated in the table.

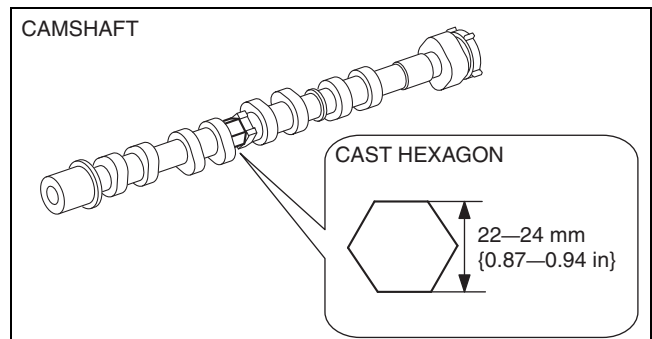

am3uuw0000902

MECHANICAL

01-10

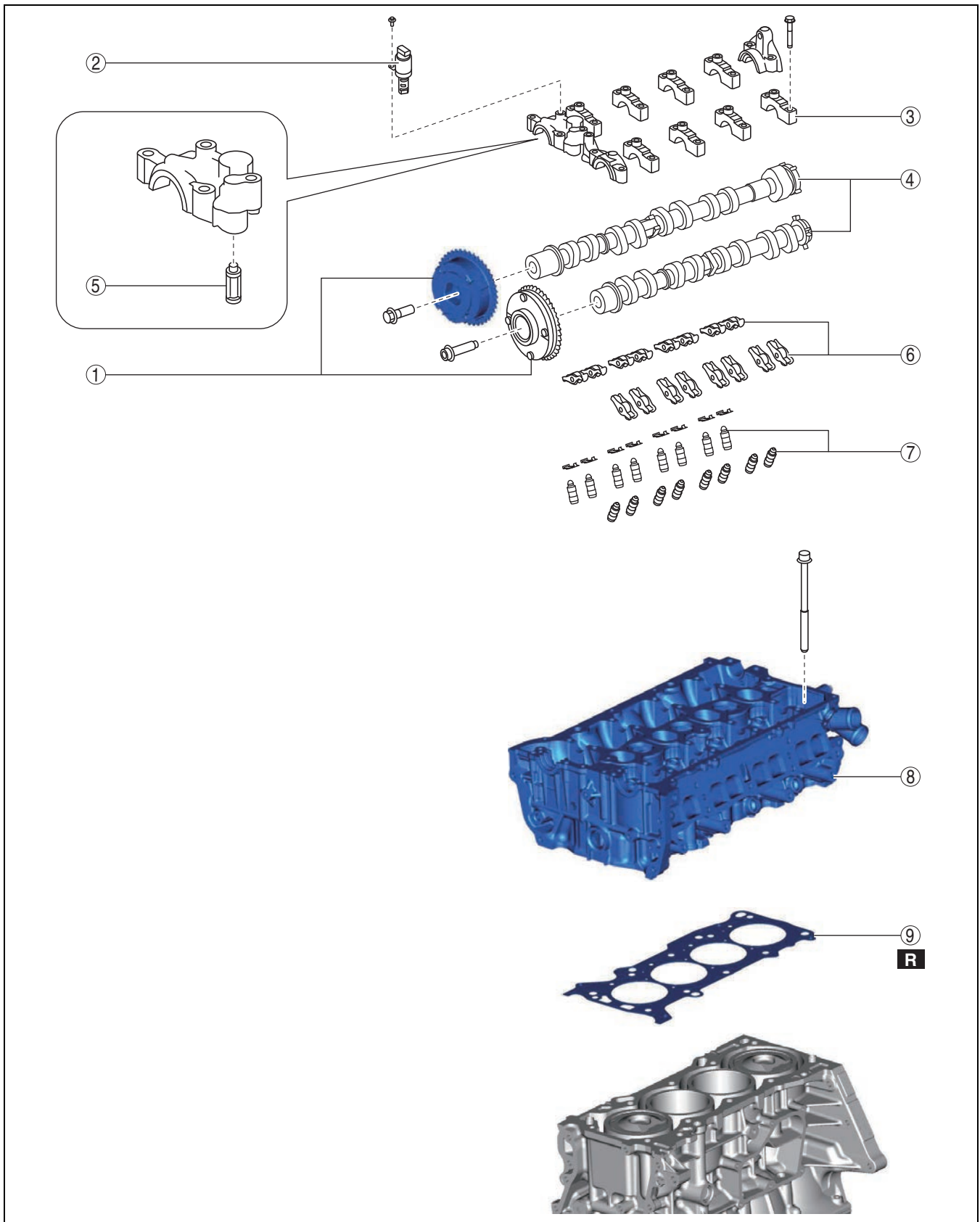

bp25ue0000095

1	Electric variable valve timing actuator, hydraulic variable valve timing actuator (See 01-10-17 Electric Variable Valve Timing Actuator, Hydraulic Variable Valve Timing Actuator Disassembly Note.)
---	---

2	OCV
3	Camshaft cap (See 01-10-17 Camshaft Cap Disassembly Note.)
4	Camshaft
5	OCV oil filter

MECHANICAL

6	Rocker arm (See 01-10-17 Rocker Arm Disassembly Note.)
7	HLA (See 01-10-17 HLA Disassembly Note.)

8	Cylinder head (See 01-10-18 Cylinder Head Disassembly Note.)
9	Cylinder head gasket

Electric Variable Valve Timing Actuator, Hydraulic Variable Valve Timing Actuator Disassembly Note

1. Hold the camshaft using a wrench on the cast hexagon and loosen the actuator installation bolt.

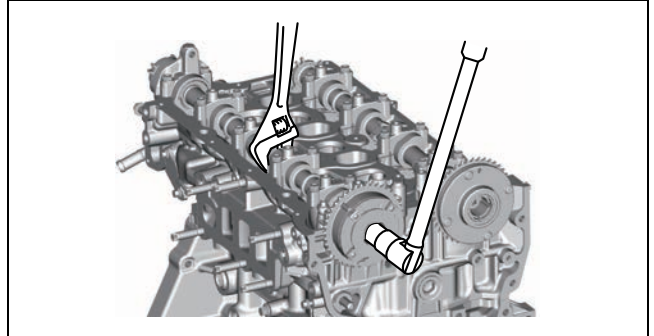

bp25ue0000004

Camshaft Cap Disassembly Note

1. Before removing the camshaft cap, inspect the camshaft end play. (See 01-10-30 CAMSHAFT INSPECTION.)
2. Loosen the camshaft cap installation bolts in two or three passes in the order shown in the figure and remove the camshaft caps.

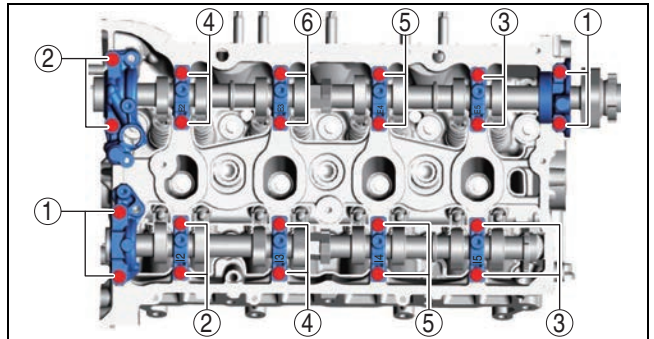

bp25ue0000005

Rocker Arm Disassembly Note

1. Remove the rocker arms, clips and HLAs as a single unit. (When exhaust side rocker arms is removed.)
2. Press the clip in the direction of the arrow to remove it, and then remove the rocker arm.
3. Keep the rocker arms in the order of removal to enable reassembly in their original positions.

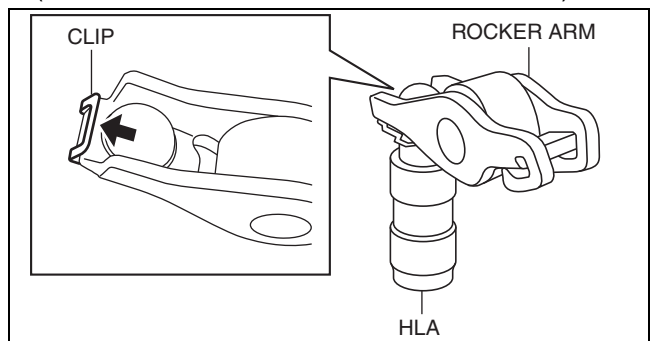

bp25ue0000006

MECHANICAL

HLA Disassembly Note

1. Remove the rocker arms, clips and HLAs as a single unit. (When exhaust side HLAs is removed.)
2. Press the clip in the direction of the arrow to remove it, and then remove the HLA.
3. Keep the HLAs in the order of removal to enable reassembly in their original positions.

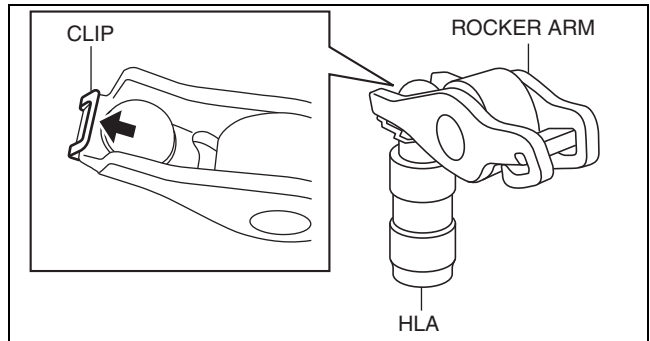

bp25ue0000006

01-10

Cylinder Head Disassembly Note

1. Loosen the cylinder head installation bolts in two or three passes in the order shown in the figure and remove them.

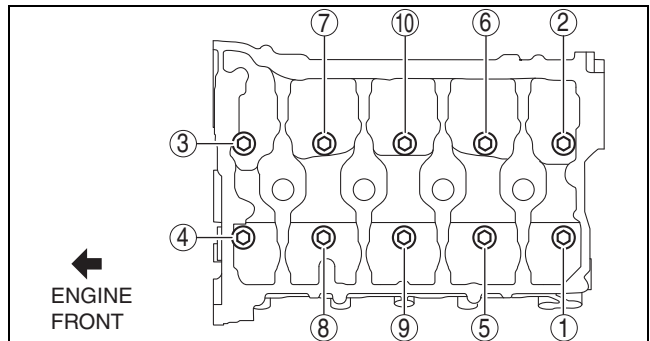

bpe2ue00000014

MECHANICAL

CYLINDER HEAD DISASSEMBLY (II)

id011000500500

Special Service Tool (SST)

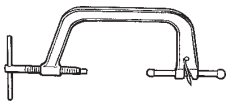
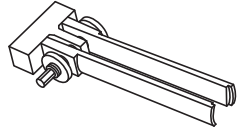
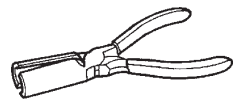
1. : Mazda SST number 2. : Global SST number					
1: 49 0636 100B 2: - Valve spring lifter arm		1: 49 B012 0A2A 2: - Pivot		1: 49 S120 170 2: - Valve seal remover	

1. Disassemble in the order indicated in the table.

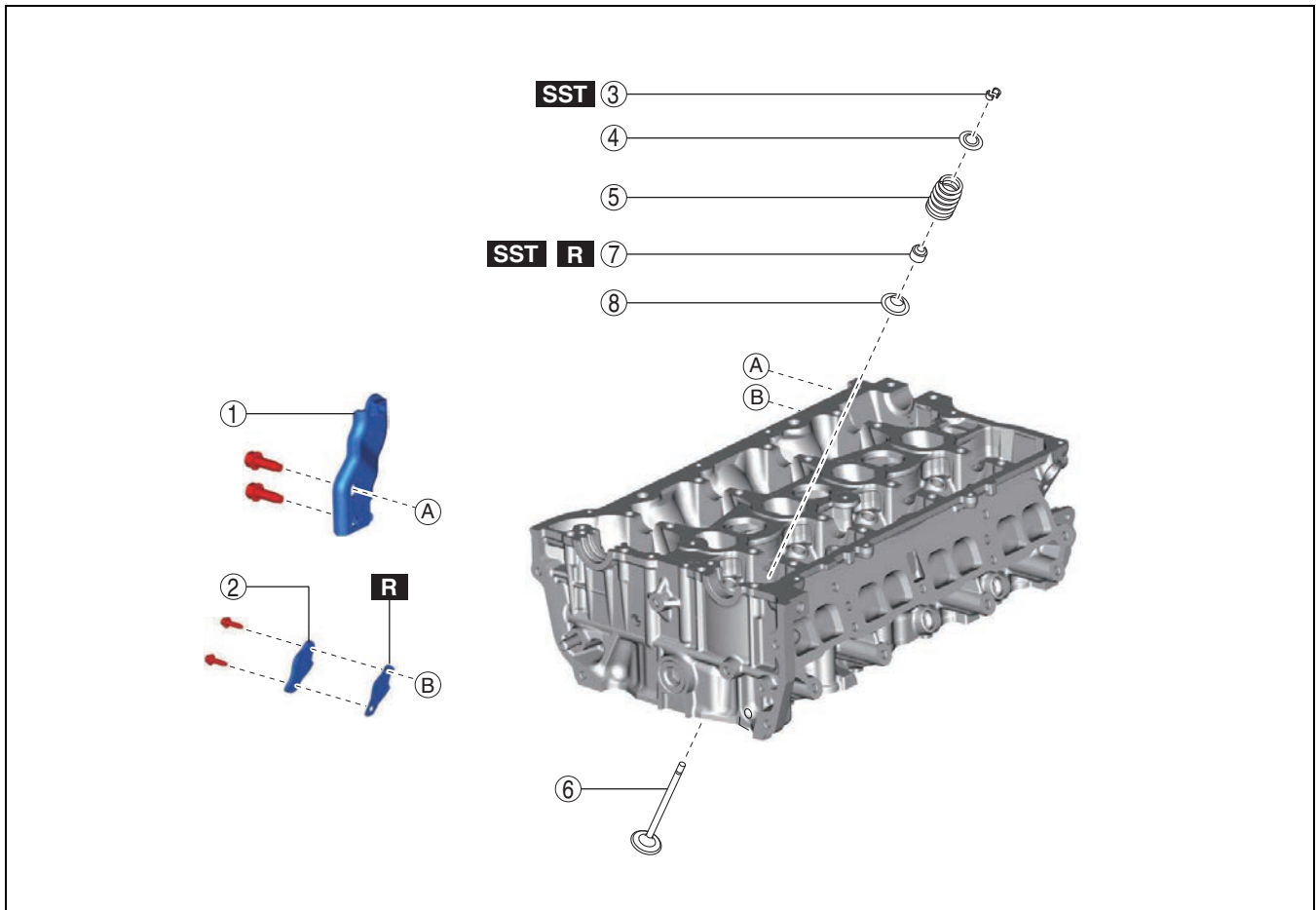

bp25ue0000079

1	Hanger bracket
2	Blind cover
3	Valve keeper (See 01-10-20 Valve Keeper Disassembly Note.)
4	Upper valve spring seat

5	Valve spring
6	Valve
7	Valve seal (See 01-10-20 Valve Seal Disassembly Note.)
8	Lower valve spring seat

MECHANICAL

Valve Keeper Disassembly Note

1. Remove the valve keeper using the SSTs.

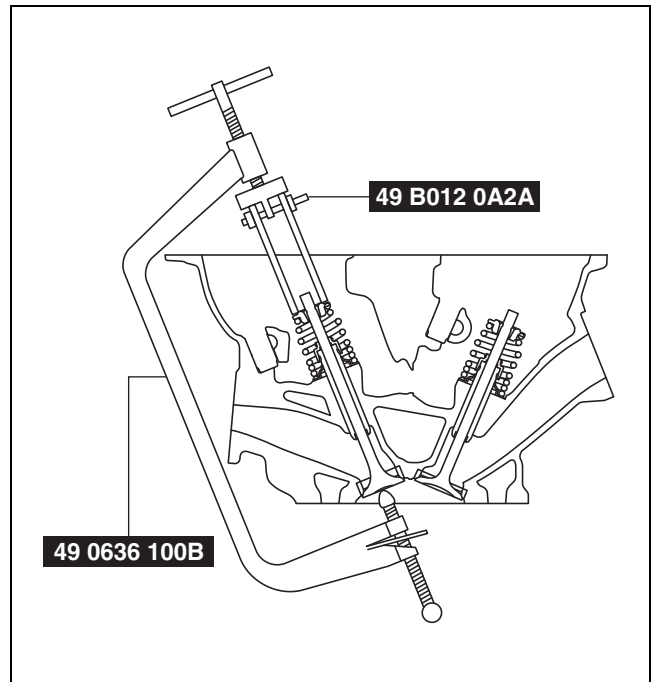

01-10

bpe1ze0000014

Valve Seal Disassembly Note

1. Remove the valve seal using the SST or pliers.

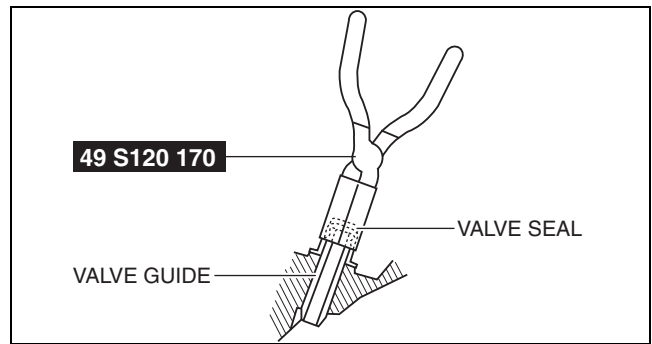

bpe1ze0000015

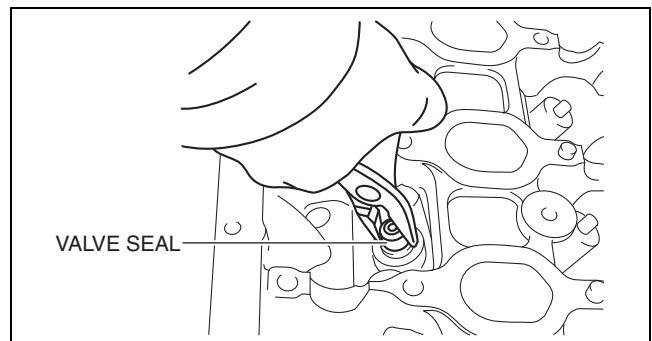

bpe1ze0000016

MECHANICAL

CYLINDER BLOCK DISASSEMBLY (I)

id011000500600

Special Service Tool (SST)

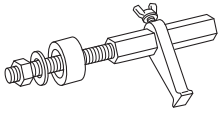
1. : Mazda SST number	
2. : Global SST number	
1: 49 E011 1A0	
2: -	
Ring gear brake set	

Caution

- Do not disassemble the oil pump and balancer unit because it is a precision unit.

1. Disassemble in the order indicated in the table.

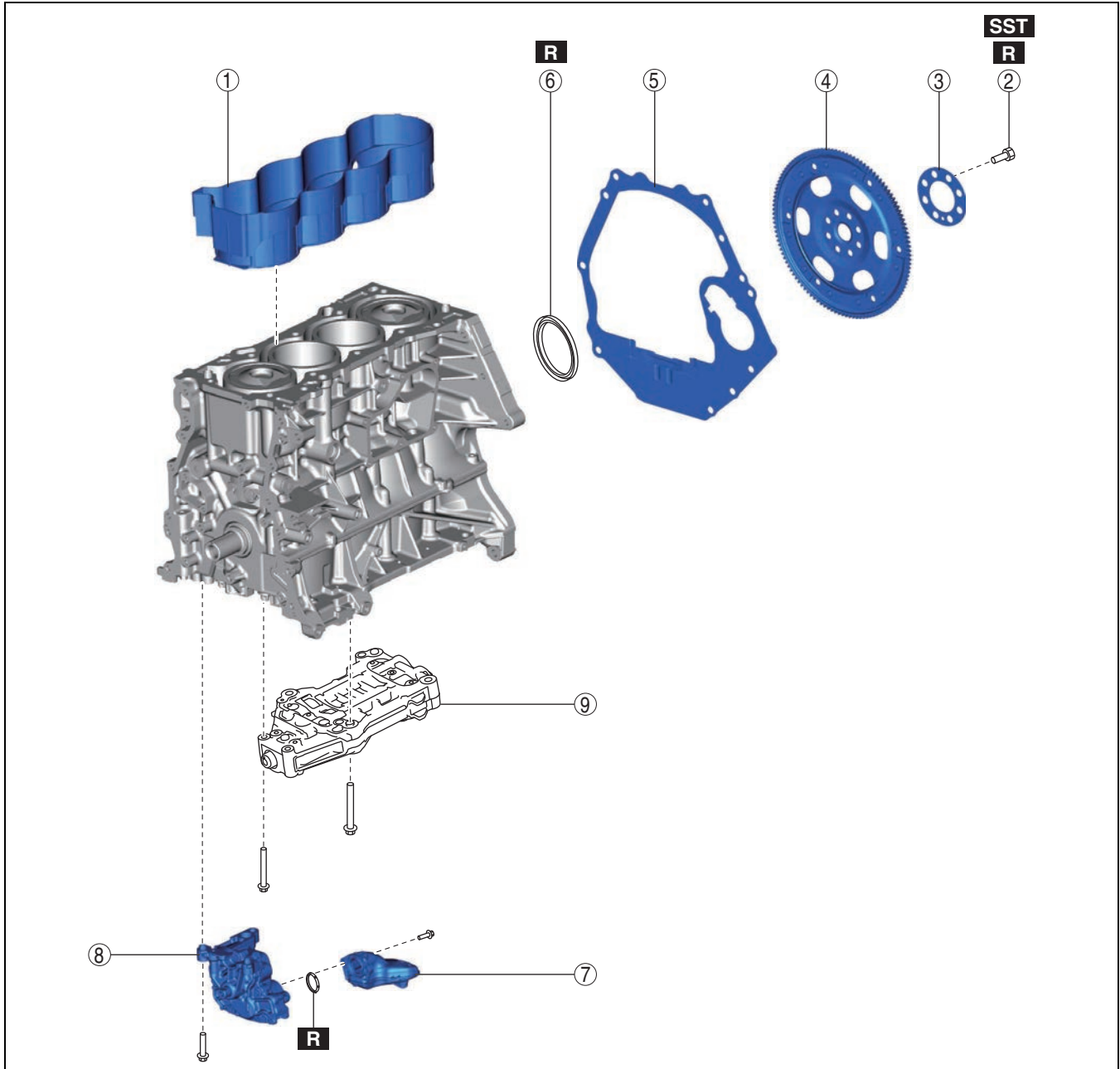

bp25ue00000008

1	Water jacket spacer
2	Drive plate installation bolt (See 01-10-22 Drive Plate Installation Bolt Disassembly Note.)

3	Backing plate
4	Drive plate
5	End plate

MECHANICAL

6	Rear oil seal (See 01-10-22 Rear Oil Seal Disassembly Note.)
7	Oil strainer

8	Oil pump
9	Balancer unit

Drive Plate Installation Bolt Disassembly Note

1. Hold the crankshaft using the **SST**.
2. Loosen the bolts uniformly and gradually in the order shown in the figure.

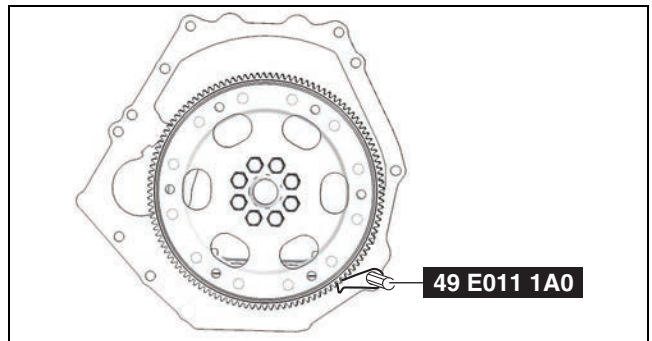

bp25ue0000084

01-10

Rear Oil Seal Disassembly Note

1. Cut the oil seal lip using a utility knife.
2. Remove the oil seal using a flathead screwdriver with the tip protected by a clean cloth to prevent damage to the oil seal sliding part of the crankshaft.

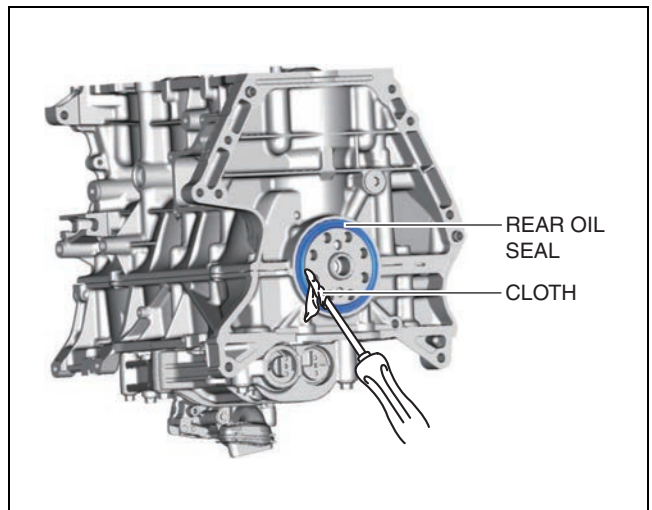

bp25ue0000010

MECHANICAL

CYLINDER BLOCK DISASSEMBLY (II)

id011000500700

1. Disassemble in the order indicated in the table.

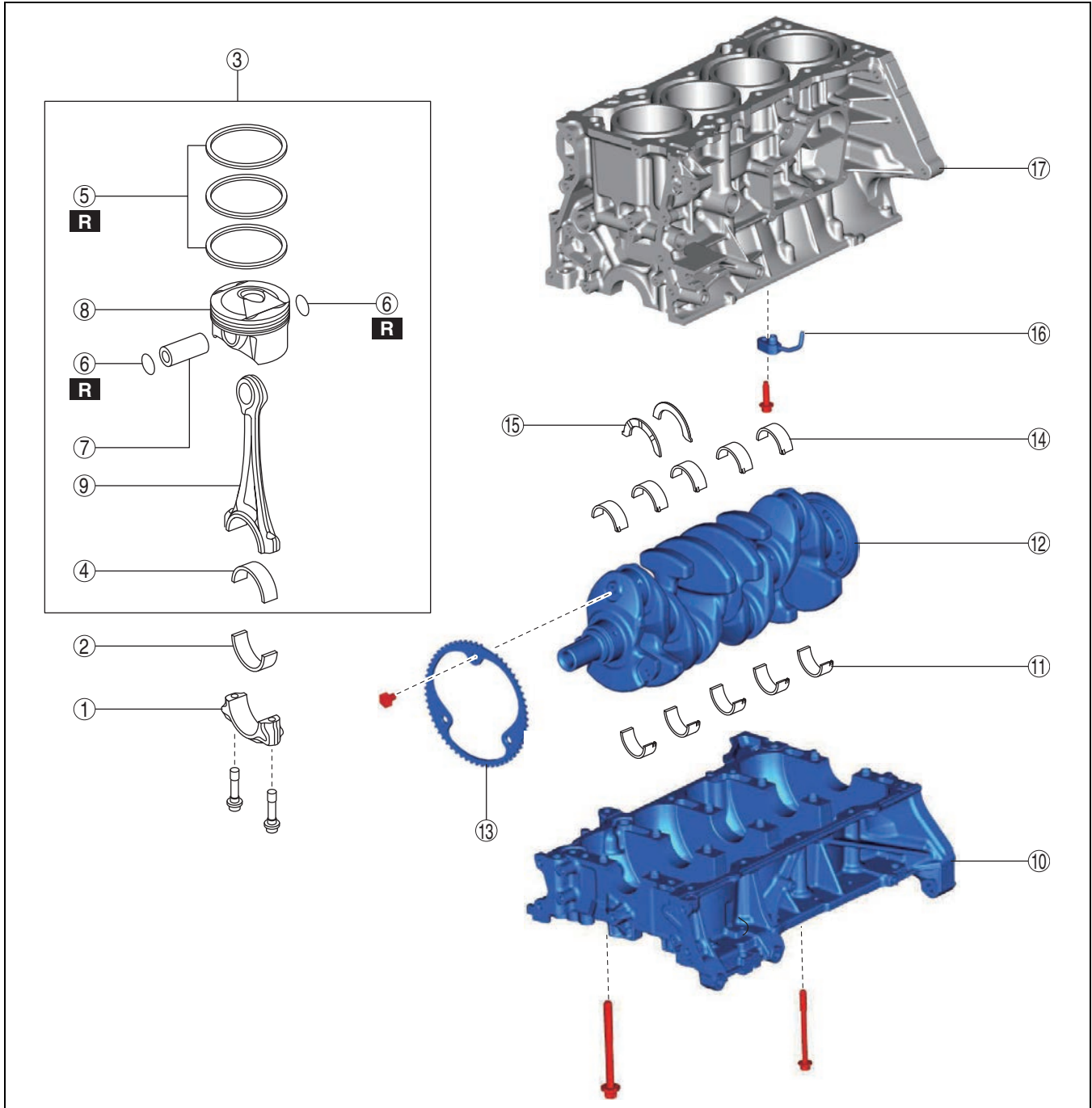

bp25ue0000096

1	Connecting rod cap (See 01-10-24 Connecting Rod Cap Disassembly Note.)
2	Lower connecting rod bearing (See 01-10-24 Connecting Rod Bearing Disassembly Note.)
3	Piston, connecting rod (See 01-10-24 Piston, Connecting Rod Disassembly Note.)
4	Upper connecting rod bearing (See 01-10-24 Connecting Rod Bearing Disassembly Note.)
5	Piston ring

6	Snap ring (See 01-10-24 Snap Ring Disassembly Note.)
7	Piston pin
8	Piston
9	Connecting rod
10	Lower cylinder block (See 01-10-24 Lower Cylinder Block Disassembly Note.)
11	Lower main bearing (See 01-10-25 Thrust Bearing And Main Bearing Disassembly Note.)

MECHANICAL

12	Crankshaft (See 01-10-25 Crankshaft Disassembly Note.)
13	Plate
14	Upper main bearing (See 01-10-25 Thrust Bearing And Main Bearing Disassembly Note.)

15	Thrust bearing (See 01-10-25 Thrust Bearing And Main Bearing Disassembly Note.)
16	Oil jet valve
17	Upper cylinder block

01-10

Connecting Rod Cap Disassembly Note

1. Before removing the connecting rod cap, inspect the connecting rod side clearance. (See 01-10-35 CONNECTING ROD CLEARANCE INSPECTION.)
2. The removed connecting rod caps are to be kept so that they can be assembled to the same positions and in the direction as before removal.

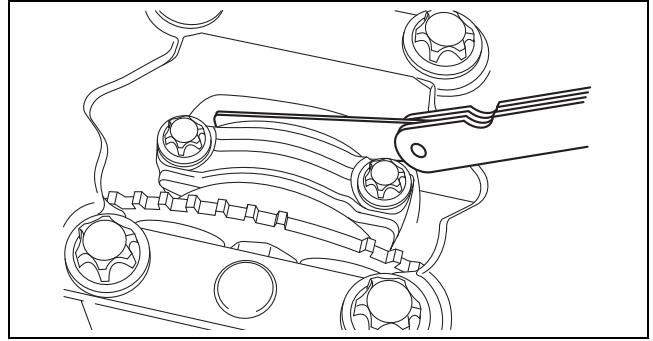

bp31je0000044

Connecting Rod Bearing Disassembly Note

1. The removed connecting rod bearings are to be kept so that they can be assembled to the same positions and in the direction as before removal.

Piston, Connecting Rod Disassembly Note

1. Before removing the piston and connecting rod, remove the carbon in the cylinder.
2. Before removing the piston and connecting rod, inspect the oil clearance at the large end of the connecting rod. (See 01-10-35 CONNECTING ROD CLEARANCE INSPECTION.)

Snap Ring Disassembly Note

1. Before removing the snap ring, verify that the large end of connecting rod drops under its own weight with no resistance. (See 01-10-35 PISTON AND CONNECTING ROD INSPECTION.)
2. Remove the snap ring using a flathead screwdriver.

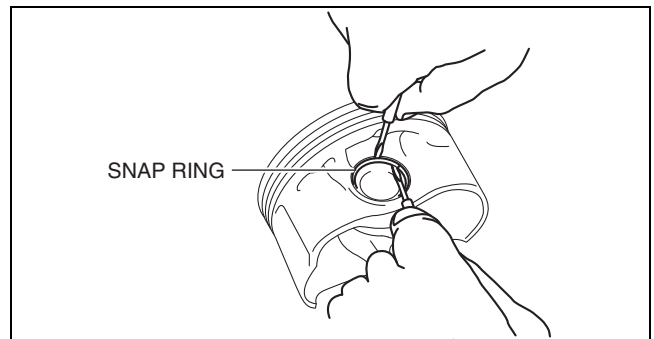

bpe2ue0000022

MECHANICAL

Lower Cylinder Block Disassembly Note

1. Before removing the lower cylinder block, inspect the crankshaft end play. (See 01-10-36 CRANKSHAFT INSPECTION.)
2. Loosen the lower cylinder block installation bolts B in two or three passes in the order shown in the figure and remove them.

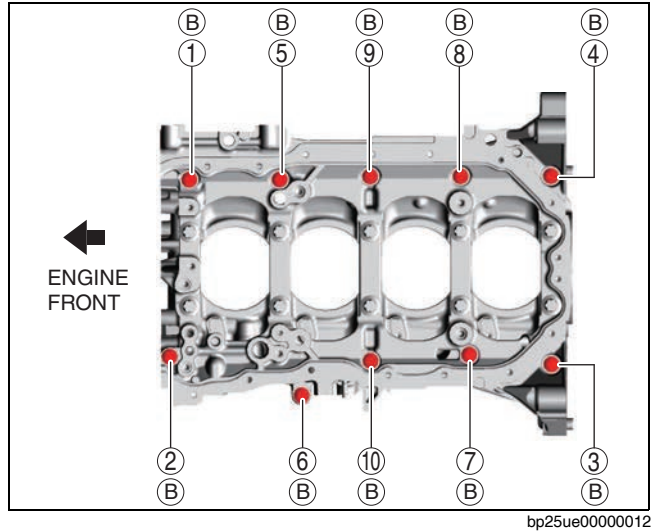

3. Loosen the lower cylinder block installation bolts A in two or three passes in the order shown in the figure and remove them.

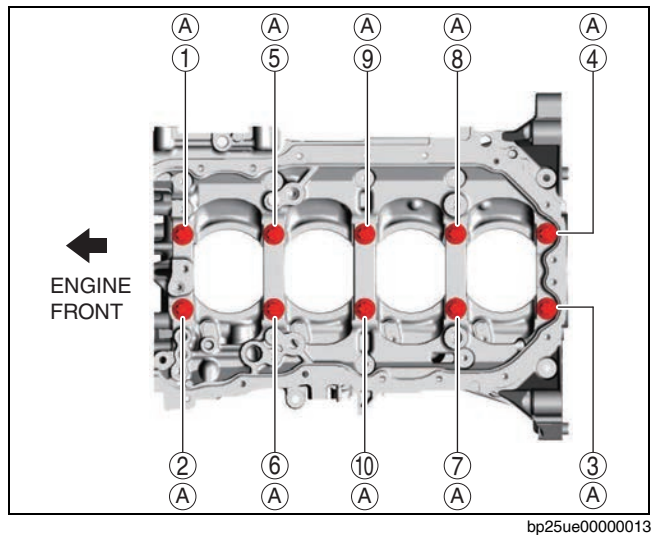

4. Using a screwdriver wrapped in a cloth, peel the sealant away a little at a time, and remove the lower cylinder block.

Caution

- Do not apply excessive force to the screwdriver. Otherwise, the lower cylinder block could be damaged.
- Be careful not to scratch or damage the seal surface. Otherwise, it could cause oil leakage.

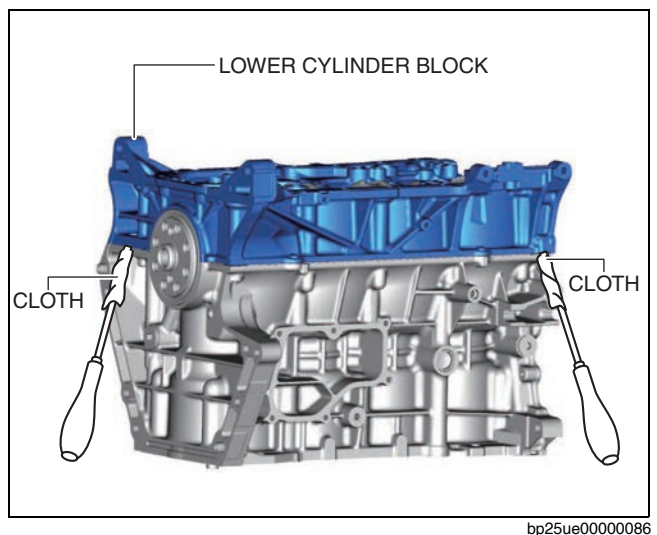

Thrust Bearing And Main Bearing Disassembly Note

1. The removed thrust bearings and main bearings are to be kept so that they can be assembled to the same positions and in the direction as before removal.

Crankshaft Disassembly Note

Caution

- Placing the crankshaft on a disassembly bench will deform or damage it because the plate for the crankshaft position sensor signal detection installed to the crankshaft is larger than the counterweight. Therefore, set wood blocks or similar objects on the both sides of the crankshaft so that the plate does not contact the disassembly bench directly when placing the crankshaft on the bench.

01-10

CYLINDER HEAD INSPECTION

id011000507100

- Inspect the cylinder head surface for cracks and other damage using a red dye penetrant.
 - If there is a malfunction, replace the cylinder head.
- Measure the combustion chamber side of the cylinder head for distortion in six directions as shown in the figure using a straight edge and feeler gauge.
 - If the distortion exceeds the maximum specification, replace the cylinder head. Do not attempt to repair the cylinder head by milling or grinding.

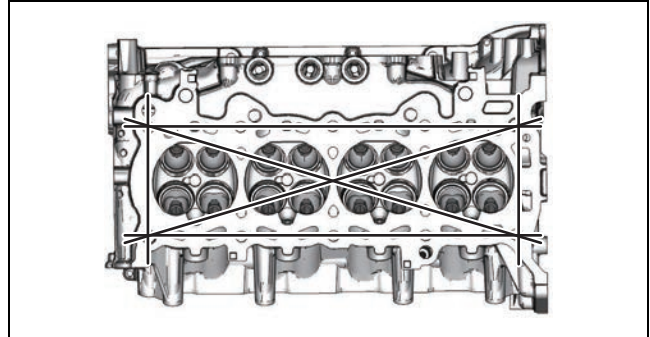

bp25ue0000077

Maximum distortion, head gasket side of the cylinder head
0.05 mm {0.002 in}

- Inspect the contact surface of the exhaust manifold and the intake manifold for distortion by measuring as shown in the figure using a straight edge and feeler gauge.
 - If the distortion on the intake manifold side exceeds the maximum specification, replace the cylinder head.
 - If the distortion on the exhaust manifold side exceeds the maximum specification, grind the surface or replace the cylinder head.

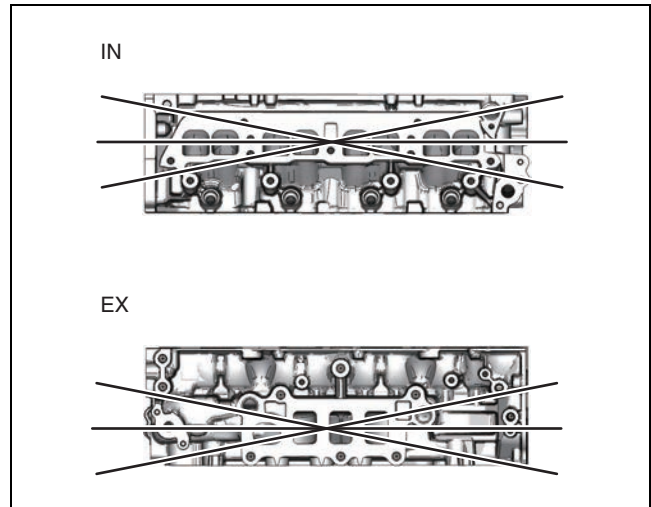

bp25ue0000078

Maximum distortion, manifold side
IN: 0.10 mm {0.0039 in}
EX: 0.05 mm {0.002 in}

Maximum cutting length, manifold side
IN: Cutting not authorized
EX: 0.20 mm {0.0079 in}

VALVE SEAT INSPECTION/REPAIR

id011000501300

- Measure the contact width of the valve face and the valve seat using the valve lapping compound.
 - If it is not within the specification, resurface the valve seat using the 45° valve seat cutter.

Standard valve seat contact width
1.37—1.84 mm {0.0540—0.0724 in}

Valve seat angle
45°

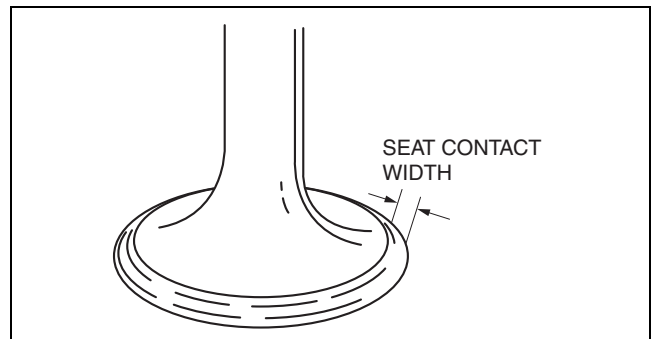

bpe1ze00000102

MECHANICAL

2. Verify that the area where the valve seat contacts the valve face is centered.

- If the seating position is too high, correct the valve seat using a 70° (IN) 70° (EX) valve seat cutter and a 45° valve seat cutter.
- If the seating position is too low, correct as follows:
 - IN: Correct the valve seat using a 20° valve seat cutter and then using a 45° valve cutter.
 - EX: Correct the valve seat using a 45° valve seat cutter.

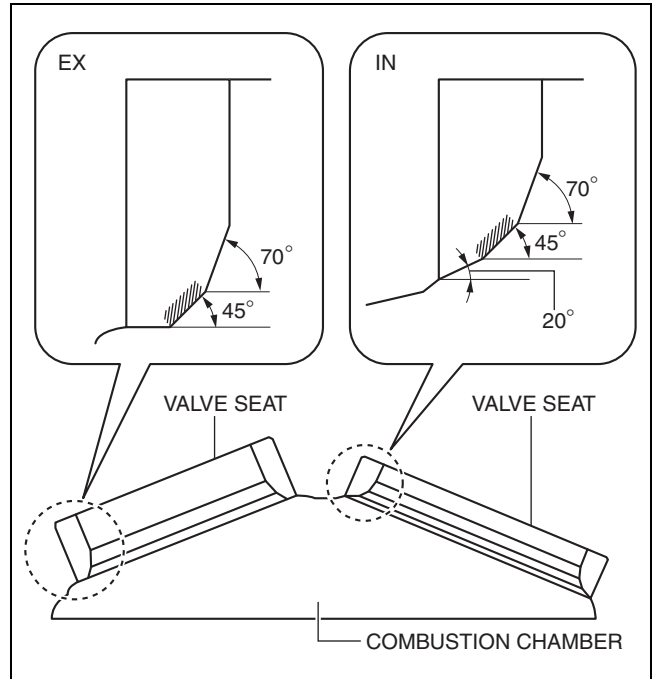

bpe1ze00000103

3. Inspect the valve seat for sinkage. Measure the protruding length (dimension L) of the valve stem using a valve of standard length.

- If it is not within the specification, replace the cylinder head.

Standard valve seat sinkage amount (Dimension L)

IN: 48.93—50.17 mm {1.927—1.975 in}
EX: 48.87—50.11 mm {1.925—1.972 in}

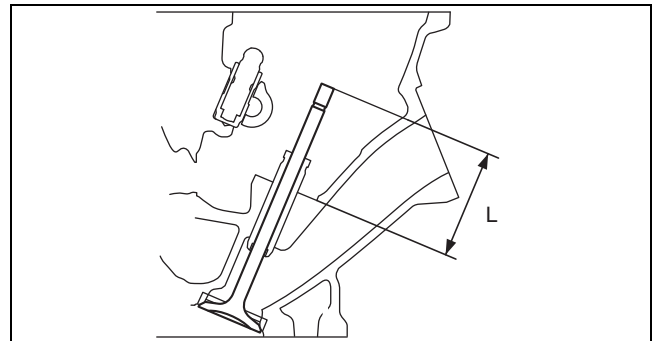

bpe1ze00000104

id011000506200

VALVE, VALVE GUIDE INSPECTION

1. Measure the valve head margin thickness using a vernier caliper.

- If it is less than the standard specification, replace the valve.

Standard valve head margin thickness

IN: 1.75—1.95 mm {0.0689—0.0767 in}
EX: 1.90—2.10 mm {0.0749—0.0826 in}

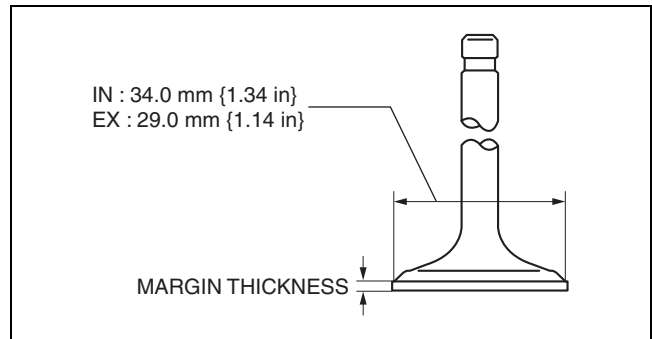

bpe5ue00000012

2. Measure the length of the each valve using a vernier caliper.
- If it is less than the minimum specification, replace the valve.

Standard valve length

IN: 107.00—107.60 mm {4.2127—4.2362 in}
EX: 117.04—117.64 mm {4.6079—4.6314 in}

Minimum valve length

IN: 106.78 mm {4.2039 in}
EX: 116.87 mm {4.6012 in}.

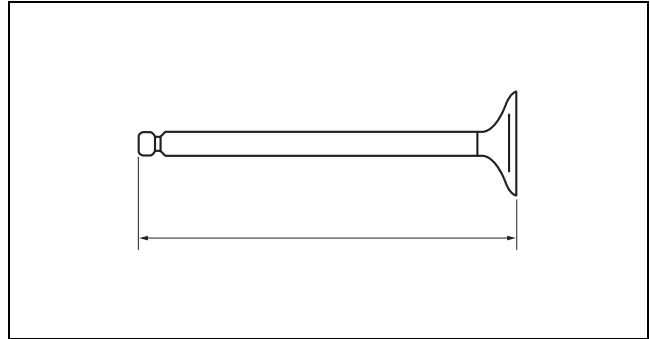

bez0je00000017

3. Measure the valve stem diameter of each valve using the micrometer. Measurement positions total six and are in the X and Y directions, at three points (A, B, and C) as shown in the figure.
- If it is less than the minimum specification, replace the valve.

Standard valve stem diameter

IN: 5.470—5.485 mm {0.2154—0.2159 in}
EX: 5.465—5.480 mm {0.2152—0.2157 in}

Minimum valve stem diameter

IN: 5.424 mm {0.2135 in}
EX: 5.419 mm {0.2133 in}

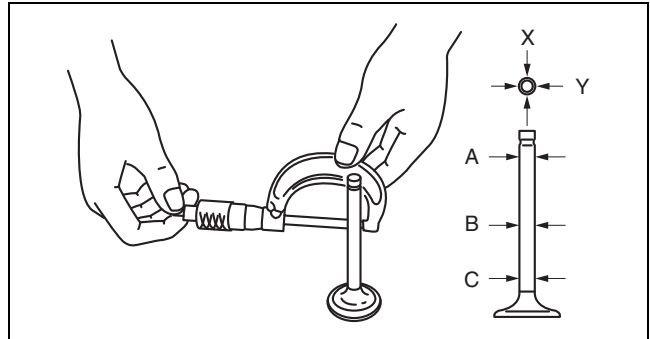

bpe2ue00000084

4. Measure the inner diameter of each valve guide using the caliper gauge. Measurement positions total six and are in the X and Y directions, at three points (A, B, and C) as shown in the figure.
- If it is not within the specification, replace the valve guide.

Standard valve guide inner diameter

IN: 5.510—5.530 mm {0.2170—0.2177 in}
EX: 5.510—5.530 mm {0.2170—0.2177 in}

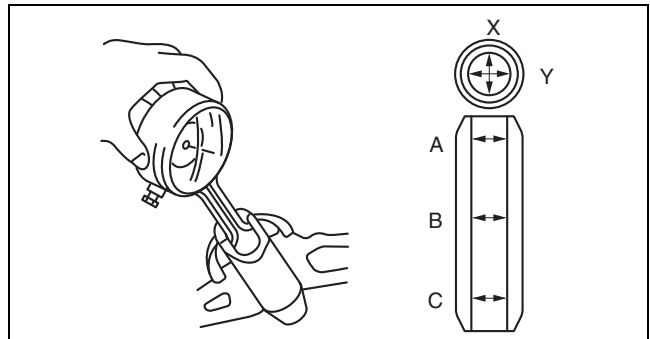

bpe2ue00000085

5. Calculate the clearance between the valve stem and the valve guide by subtracting the inner diameter of the valve guide from the outer diameter of the corresponding valve stem.
- If it exceeds the maximum specification, replace the valve or valve guide.

Standard clearance between valve stem and guide

IN: 0.025—0.060 mm {0.0010—0.0023 in}
EX: 0.030—0.065 mm {0.0012—0.0025 in}

Maximum clearance between valve stem and guide

0.10 mm {0.0039 in}

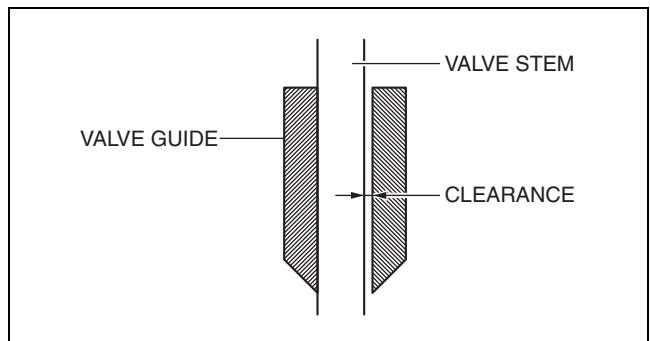

bpe2ue00000086

MECHANICAL

- Measure the projection height (dimension A) of each valve guide using the vernier caliper.
 - If it is not within the specification, replace the valve guide.

Standard valve guide projection height

IN: 16.4—17.0 mm {0.646—0.669 in}

EX: 16.4—17.0 mm {0.646—0.669 in}

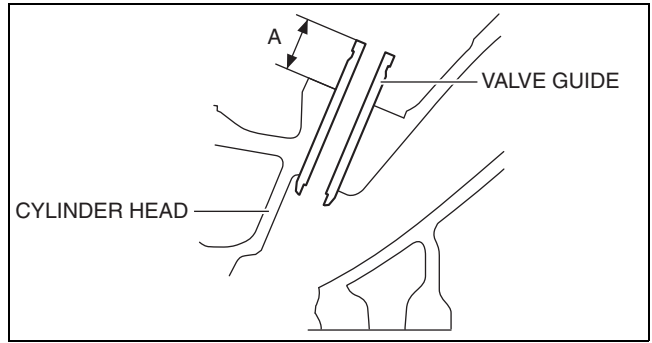

bpe2ue0000087

id011000501200

VALVE GUIDE REPLACEMENT

Special Service Tool (SST)

- Mazda SST number
- Global SST number

1: 49 B012 015

2: -

Valve guide installer

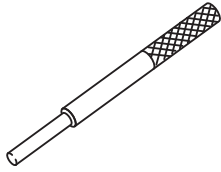

Removal

- Tap the valve guide out from combustion chamber side using the **SST**.

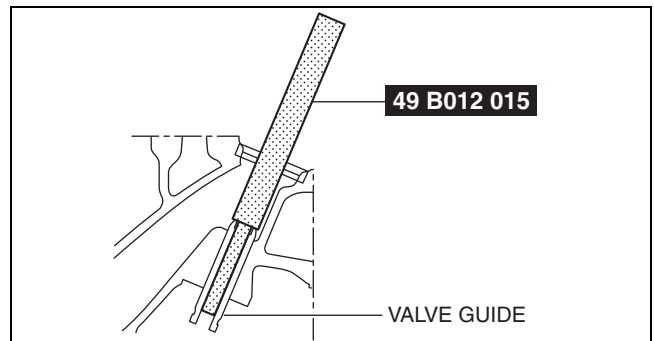

bpe2ue0000026

Installation

- Apply clean engine oil to the valve guide.
- Tap the valve guide from the camshaft side using the SST so that the projection height (dimension A) is within the specification.

Standard valve guide projection height

IN: 16.4—17.0 mm {0.646—0.669 in}

EX: 16.4—17.0 mm {0.646—0.669 in}

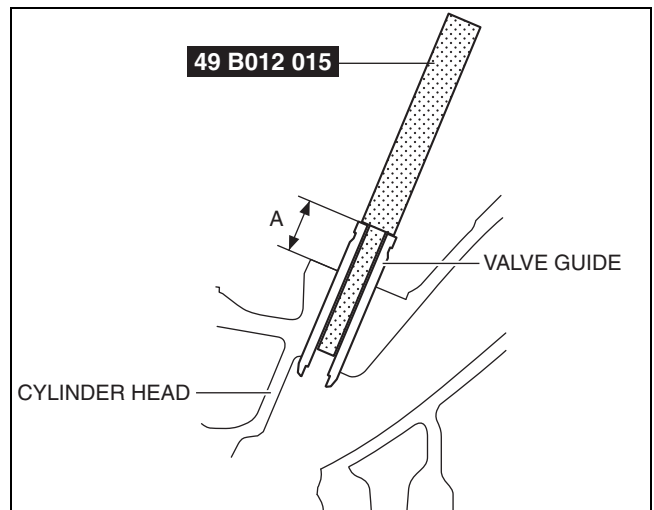

bpe2ue0000027

VALVE SPRING INSPECTION

id011000501400

Caution

- The valve springs differ depending on the IN and EX sides. Therefore, verify the free length or identification paint beforehand and inspect the valve springs.

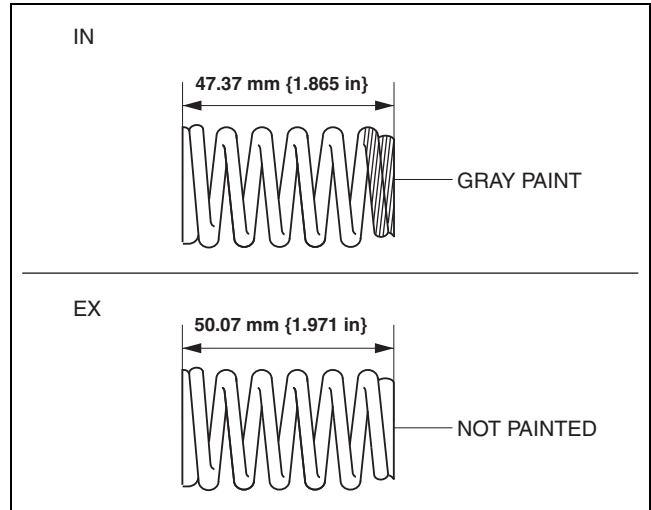

bp25ue00000018

1. Measure the valve spring height using the spring tester.

- If it is not within the specification, replace the valve spring.

Valve spring installation height

IN: When pressurized with spring force of 195—215 N {19.9—21.9 kgf, 43.9—48.3 lbf}, spring height is 38.0 mm {1.50 in}

EX: When pressurized with spring force of 228—252 N {23.3—25.6 kgf, 51.3—56.6 lbf}, spring height is 38.0 mm {1.50 in}

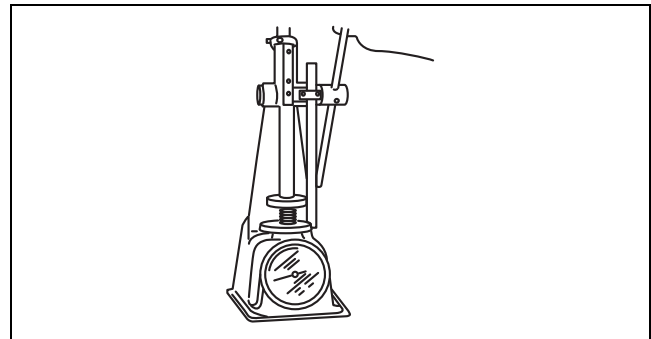

bpe5ue00000041

2. Measure the amount of off-square on the valve spring using a square.

- (1) Rotate the valve spring one full turn and measure A at the point where the gap is the largest.

- If it exceeds the maximum specification, replace the valve spring.

Maximum valve spring off-square

IN: 2.0 ° (3.6 mm {0.14 in})

EX: 2.0 ° (3.6 mm {0.14 in})

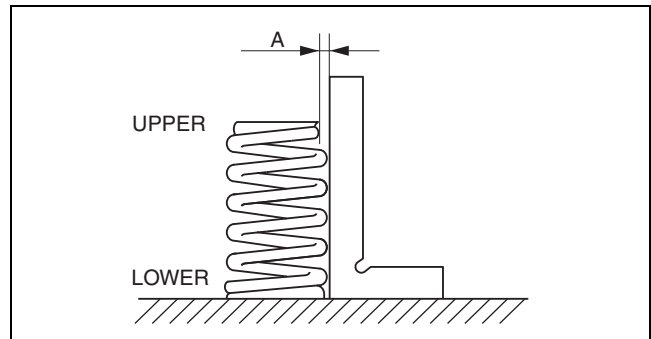

bpe5ue00000042

CAMSHAFT INSPECTION

id011000501500

1. Set the No.1 and No.5 journals of the camshaft on V-blocks.
2. Measure the camshaft runout using the dial gauge.

- If it exceeds the maximum specification, replace the camshaft.

Maximum camshaft runout

0.030 mm {0.0012 in}

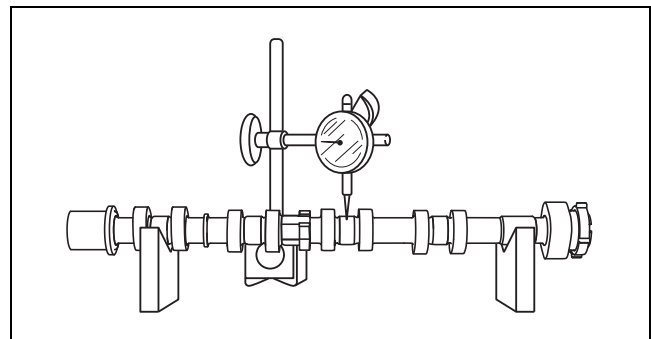

bpe2ue00000031

MECHANICAL

3. Measure the cam height using the micrometer as shown in the figure.
- If it is less than the minimum specification, replace the camshaft.

Standard cam height

IN: 42.34 mm {1.667 in}

EX: 40.35 mm {1.589 in}

Minimum cam height

IN: 42.27 mm {1.664 in}

EX: 40.28 mm {1.586 in}

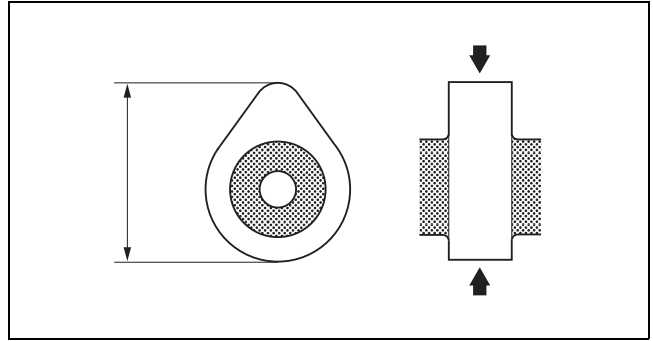

bp31je00000171

4. Measure the journal diameter using the micrometer. Measurement positions total four and are in the X and Y directions, at two points (A and B) as shown in the figure.
- If it is less than the minimum specification, replace the camshaft.

Standard camshaft journal diameter

24.96—24.98 mm {0.9827—0.9834 in}

Minimum camshaft journal diameter

24.93 mm {0.9815 in}

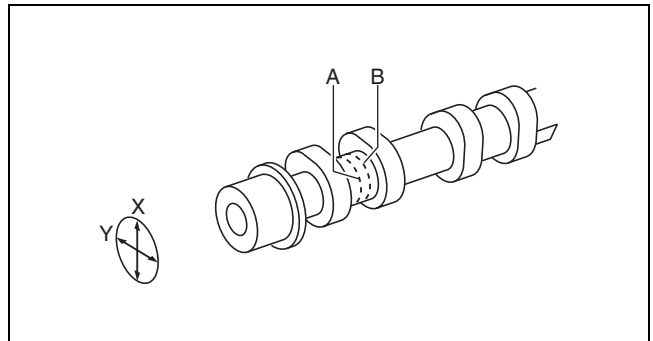

bp31je00000172

5. Measure the camshaft journal oil clearance using the following procedure:
- (1) Clean the camshaft journal and the journal receptacle part.
 - (2) Put the camshaft on the cylinder head with the rocker arm detached.
 - (3) Cut the plastigauge to the same length as the journal width and position it parallel to the camshaft.
 - (4) Install the camshaft caps. (See 01-10-54 CYLINDER HEAD ASSEMBLY (II).)
 - (5) Remove the camshaft caps. (See 01-10-15 CYLINDER HEAD DISASSEMBLY (I).)
 - (6) Measure the camshaft journal oil clearance.
 - If it exceeds the maximum specification, replace the cylinder head.

Standard camshaft journal oil clearance

0.035—0.080 mm {0.0014—0.0031 in}

Maximum camshaft journal oil clearance

0.090 mm {0.0035 in}

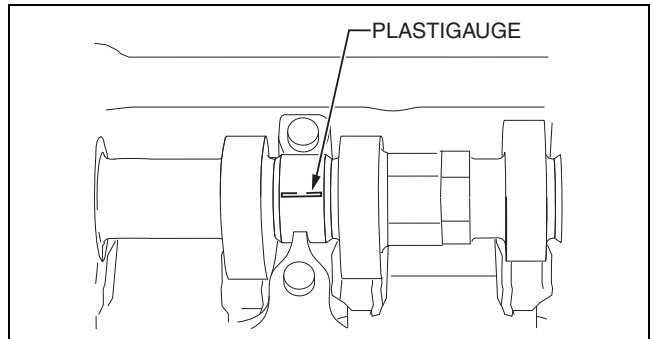

bpe2ue00000032

- Measure the camshaft end play using a dial gauge.
 - If it exceeds the maximum specification, replace the cylinder head or camshaft.

Standard camshaft end play
 0.07—0.22 mm {0.003—0.008 in}

Maximum camshaft end play
 0.98 mm {0.039 in}

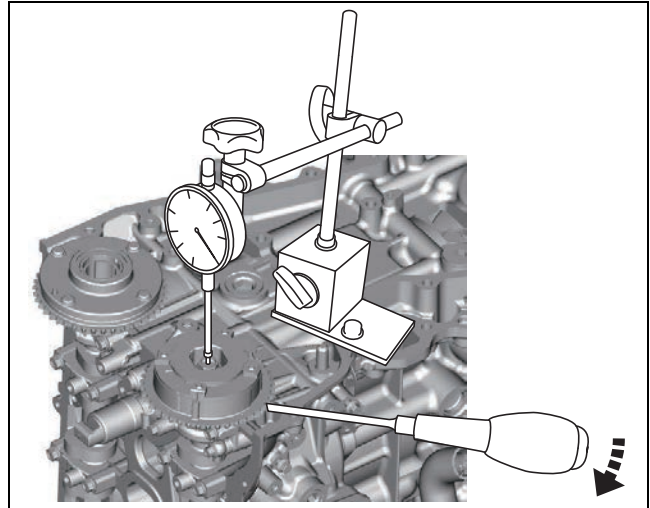

bp25ue0000015

CYLINDER BLOCK INSPECTION

- Measure the cylinder block for distortion in six directions as shown in the figure using a straight edge and feeler gauge.
 - If it exceeds the maximum specification, replace the cylinder block.

Maximum distortion, head gasket side of the cylinder block
 0.10 mm {0.0039 in}

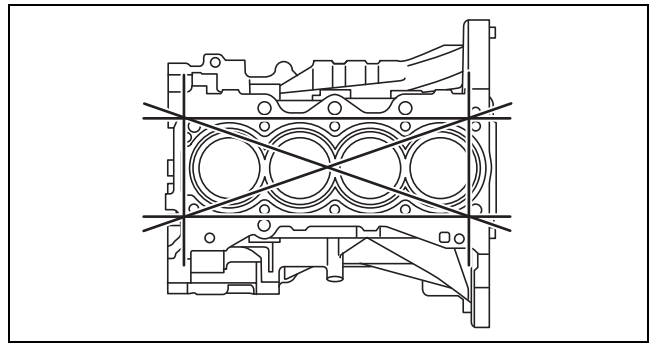

id011000507200

bp31je00000144

- Measure the cylinder bore diameter using the cylinder gauge. The measurement position is in the X and Y directions at a point **43.9 mm {1.73 in}** below the top surface of the cylinder as shown in the figure.
 - If it is not within the specification, replace the cylinder block.

Standard cylinder bore diameter
 89.000—89.030 mm {3.5040—3.5051 in}

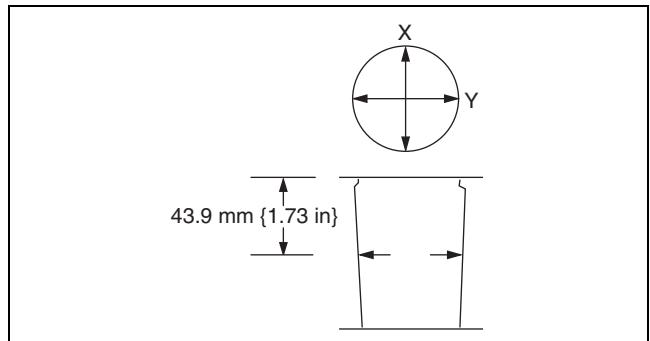

bpe2ue00000098

OIL JET VALVE INSPECTION

- Apply compressed air to oil jet valve A and verify that air passes through oil jet valve B.
 - If air does not flow, replace the oil jet valve.
 - If there is air flow with air compressor of less than **180 kPa {1.84 kgf/cm², 26.1 psi}**, replace the oil jet valve.

Oil jet valve opening pressure
 180—220 kPa {1.84—2.24 kgf/cm², 26.2—31.9 psi}

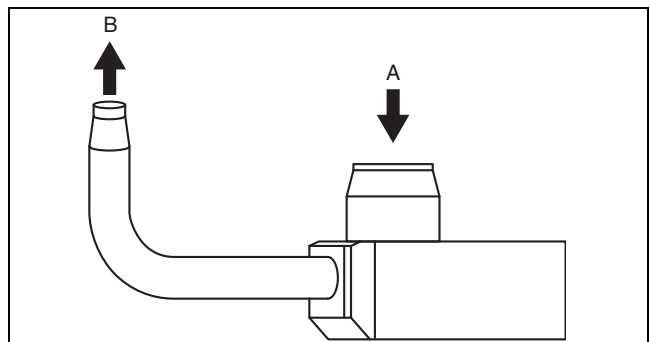

id011000505900

bp31je00000131

PISTON INSPECTION

id011000502100

Caution

- If the piston is replaced, replace the piston, piston pin, and the snap ring as a single component.

1. Measure the piston outer diameter using the micrometer. The measurement position is **12.0 mm {0.472 in}** from the lower end of the piston (area with no coating on the piston skirt) and in the thrust direction.
 - If it is not within the specification, replace the piston.

Standard piston outer diameter

88.965—88.995 mm {3.5026—3.5037 in}

2. Measure the cylinder bore diameter. (See 01-10-32 CYLINDER BLOCK INSPECTION.)
3. Calculate the cylinder-to-piston clearance from the cylinder bore diameter and the piston outer diameter.
 - If the clearance exceeds the maximum specification, replace the piston or cylinder block.

Standard clearance between piston and cylinder

0.025—0.045 mm {0.0010—0.0017 in}

Maximum clearance between piston and cylinder

0.066 mm {0.0026 in}

4. Measure the piston-to-ring groove clearance along the perimeter using a feeler gauge. For the O-ring, measure the clearance with the O-ring assembled to the piston.
 - If the clearance exceeds the maximum specification, replace the piston or piston ring.

Standard clearance between piston ring and ring groove

Top: 0.04—0.08 mm {0.002—0.003 in}

Second: 0.03—0.07 mm {0.0012—0.0027 in}

Oil: 0.04—0.12 mm {0.002—0.004 in}

Maximum clearance between piston ring and ring groove

Top: 0.12 mm {0.0047 in}

Second: 0.10 mm {0.0039 in}

Oil: 0.17 mm {0.0067 in}

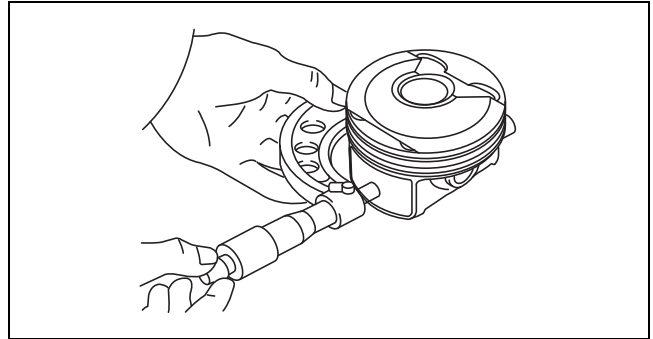

bp25ue00000016

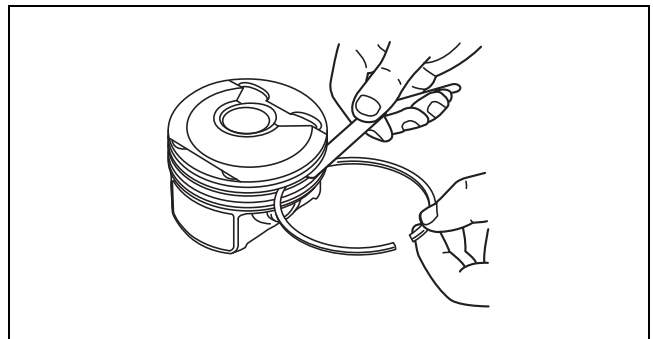

bp25ue00000017

PISTON RING INSPECTION

id011000592300

1. Using the piston, press the piston ring parallel into the cylinder to **43.9 mm {1.73 in}** from the upper end of the cylinder block.

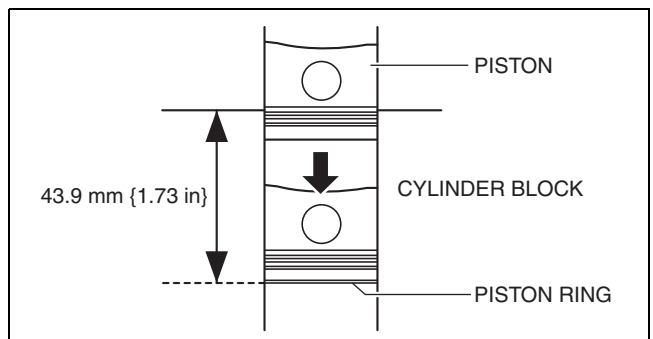

bp25ue00000094

2. Measure the piston ring end gap using a feeler gauge.
 - If it exceeds the maximum specification, replace the piston ring.

Standard piston ring end gap

Top: 0.13—0.18 mm {0.0052—0.0070 in}
Second: 0.18—0.28 mm {0.008—0.011 in}
Oil (Rail): 0.10—0.35 mm {0.004—0.013 in}

Maximum piston ring end gap

Top: 0.35 mm {0.014 in}
Second: 0.45 mm {0.018 in}
Oil (Rail): 0.52 mm {0.020 in}

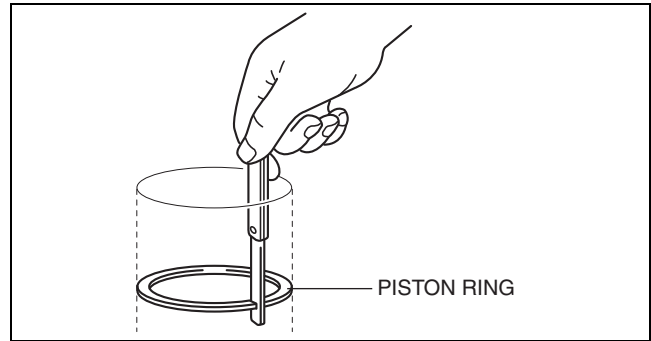

bpe2ue0000095

01-10

PISTON PIN INSPECTION

id011000507500

Caution

- If the piston or piston pin is replaced, replace the piston, piston pin and the snap ring as a single component.

1. Measure the piston pin outer diameter using the micrometer. Measurement positions total eight and are in the X and Y directions, at four points (A, B, C, and D) as shown in the figure.

Standard piston pin outer diameter

22.495—22.500 mm {0.88564—0.88582 in}

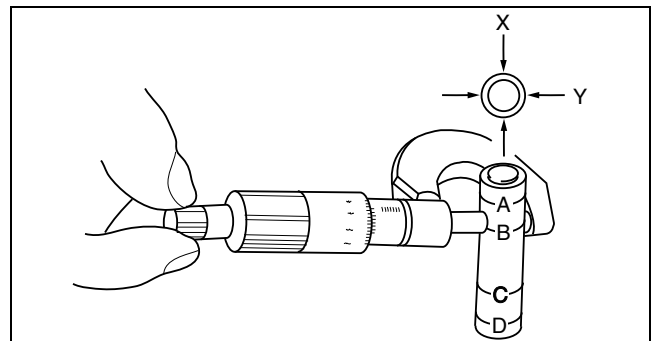

adj2224e255

2. Measure the piston pin hole diameter using the caliper gauge. Measurement positions total eight and are in the X and Y directions, at four points (A, B, C, and D) as shown in the figure.

Standard piston pin hole diameter

22.504—22.508 mm {0.88599—0.88614 in}

3. Calculate the clearance between the piston pin hole diameter and the piston pin outer diameter.
 - If it is not within the specification, replace the piston or the piston pin.

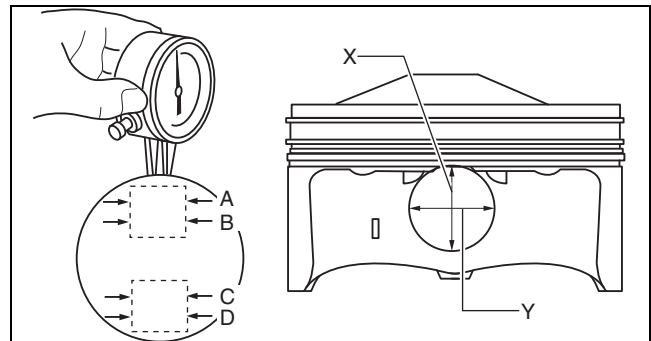

bpe1ze0000085

Standard clearance between piston pin hole diameter and piston pin outer diameter
0.004—0.013 mm {0.0002—0.0005 in}

MECHANICAL

- Measure the inner diameter on the small end of the connecting rod using the caliper gauge in the X and Y directions as shown in the figure.

Standard connecting rod small end inner diameter
22.502—22.513 mm {0.88591—0.88633 in}

- Calculate the clearance between the inner diameter on the small end of the connecting rod and the piston pin outer diameter.
 - If it is not within the specification, replace the connecting rod or the piston pin.

Standard clearance between connecting rod small end inner diameter and piston pin outer diameter
0.002—0.018 mm {0.00008—0.00070 in}

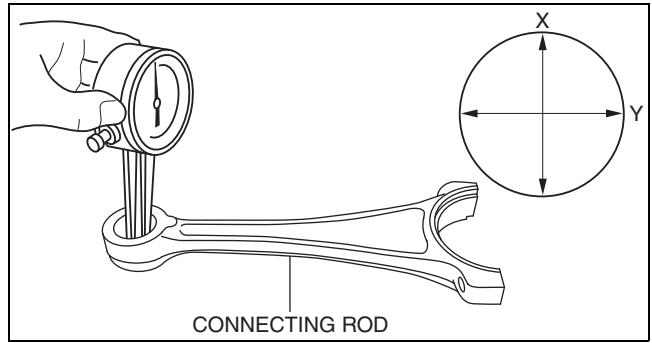

bpe2ue0000092

PISTON AND CONNECTING ROD INSPECTION

- Check the oscillation torque as shown in the figure. Verify that the large end drops under its own weight with no resistance.
 - If the piston shakes heavily or unsmoothly, disassemble the piston and connecting rod, then inspect the following: (See 01-10-34 PISTON PIN INSPECTION.)
 - Clearance between piston pin outer diameter and piston pin hole diameter.
 - Clearance between piston pin outer diameter and connecting rod small end inner diameter.

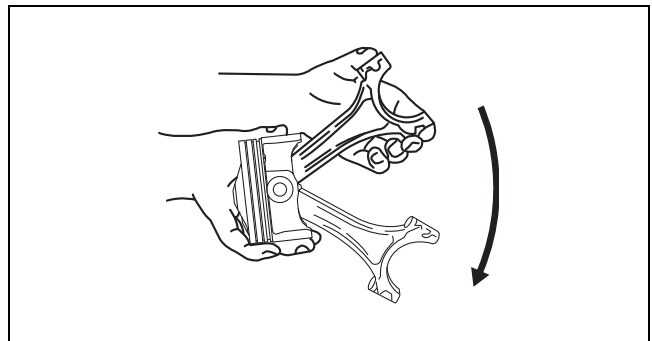

id011000503100

bp31je0000061

CONNECTING ROD INSPECTION

- Inspect the connecting rod for bending and distortion using the connecting rod aligner.
 - If it exceeds the maximum specification, replace the connecting rod.

Maximum connecting rod bending
0.050 mm {0.0020 in}

Maximum connecting rod distortion
0.050 mm {0.0020 in}

Connecting rod center-to-center distance
150.32 mm {5.9181 in}

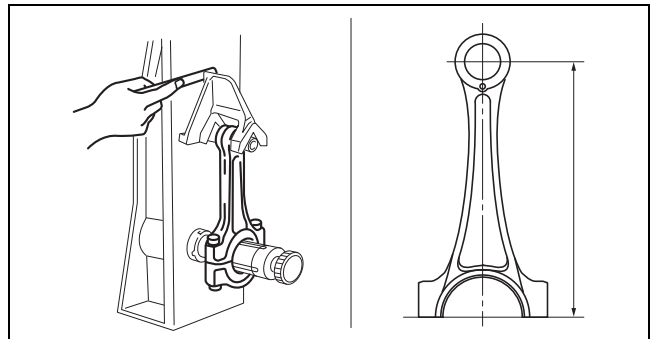

id011000502800

bpe2ue0000036

CONNECTING ROD CLEARANCE INSPECTION

- Measure the side clearance at the large end of the connecting rod using a feeler gauge.
 - If it exceeds the maximum specification, replace the connecting rod or crankshaft.

Standard side clearance at the large end of connecting rod
0.14—0.36 mm {0.006—0.014 in}

Maximum side clearance at the large end of connecting rod
0.465 mm {0.0183 in}

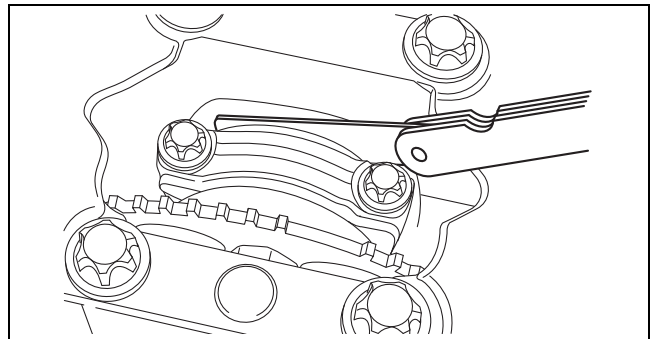

id011000507600

bp31je00000148

MECHANICAL

2. Measure the oil clearance at the large end of the connecting rod using the following procedure:

- (1) Cut the plastigauge as wide as the connecting rod bearing width, place it parallel to the crankshaft, avoiding the oil hole.
- (2) Install the lower connecting rod bearing and connecting rod cap. (See 01-10-38 CYLINDER BLOCK ASSEMBLY (I).)
- (3) Remove the connecting rod cap. (See 01-10-22 CYLINDER BLOCK DISASSEMBLY (II).)
- (4) Measure the oil clearance at the large end of the connecting rod.
 - If it exceeds the maximum specification, replace the bearing or grind the crank pin and use oversize bearings so that the specified clearance is obtained.

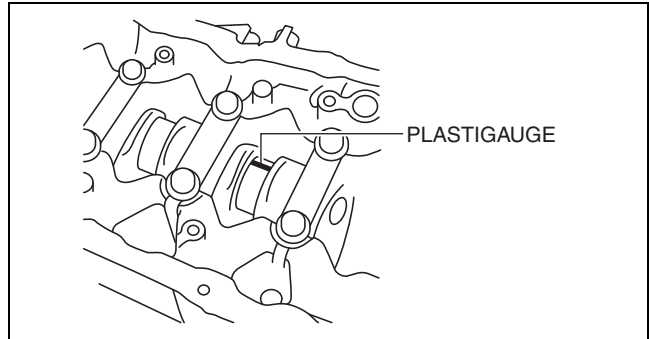

bpe2ue0000093

01-10

Standard bearing oil clearance at the large end of the connecting rod
0.026—0.052 mm {0.0011—0.0020 in}

Maximum bearing oil clearance at the large end of the connecting rod
0.10 mm {0.0039 in}

Connecting rod bearing size (upper)
STD: 1.498—1.516 mm {0.05898—0.05969 in}
OS 0.25: 1.624—1.631 mm {0.06394—0.06421 in}
OS 0.50: 1.749—1.756 mm {0.06886—0.06913 in}

Connecting rod bearing size (lower)
STD: 1.502—1.519 mm {0.05914—0.05980 in}
OS 0.25: 1.628—1.631 mm {0.06410—0.06421 in}
OS 0.50: 1.753—1.756 mm {0.06902—0.06913 in}

CRANKSHAFT INSPECTION

1. Measure the crankshaft end play using a dial gauge.
 - If it exceeds the maximum specification, replace the crankshaft or grind the thrust side of crankshaft and use the oversize thrust bearing so that the specified end play is obtained.

Standard crankshaft end play
0.08—0.29 mm {0.004—0.011 in}

Maximum crankshaft end play
0.30 mm {0.012 in}

Thrust bearing size
STD: 2.500—2.550 mm {0.0985—0.1003 in}
OS 0.25: 2.625—2.675 mm {0.1034—0.1053 in}

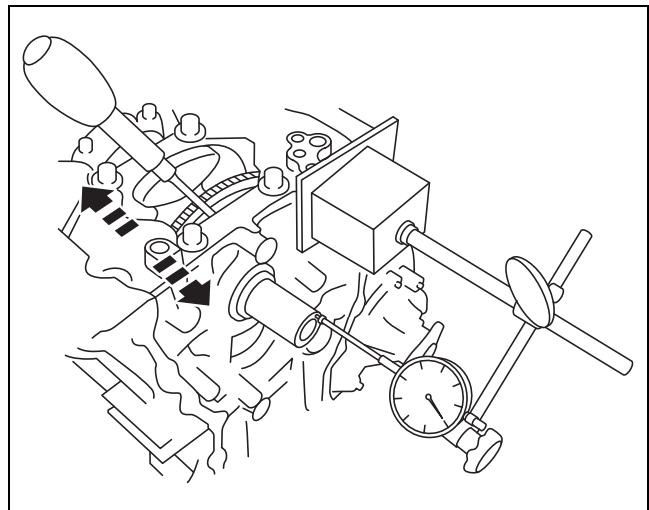

id011000502500

bp31je00000217

MECHANICAL

2. Measure the runout of the main journal using a V-block and dial gauge.
 - If it exceeds the maximum specification, replace the crankshaft.

Maximum main journal runout
0.10 mm {0.0039 in}

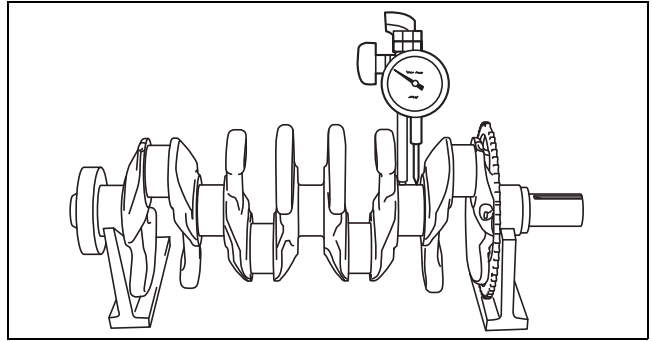

bpe2ue0000035

3. Inspect the main journal diameter and crank pin diameter. Measurement positions total four and are in the X and Y directions, at two points (A and B) as shown in the figure.
 - If it is not within the specification or if it exceeds the maximum off-round, grind the journal with an oversized bearing.

Standard main journal diameter
49.980—50.000 mm {1.9678—1.9685 in}

Maximum main journal off-round
0.005 mm {0.0002 in}

Standard crank pin diameter
49.980—50.000 mm {1.9678—1.9685 in}

Maximum crank pin off-round
0.005 mm {0.0002 in}

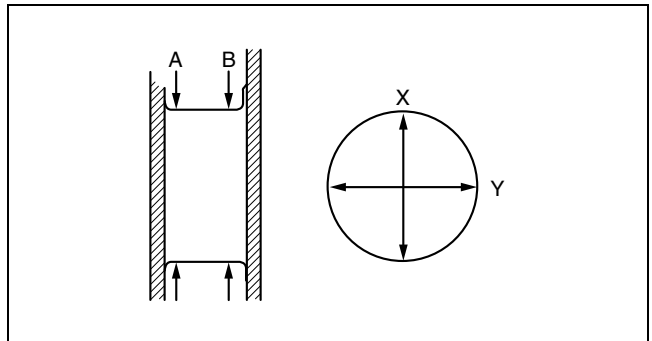

b3e0110e085

4. Inspect the main journal oil clearance using the following procedure:
 - (1) Install the thrust bearing, upper main bearing and crankshaft.
 - (2) Position a plastigauge on the journals.
 - (3) Install the lower main bearing and lower cylinder block. (See 01-10-38 CYLINDER BLOCK ASSEMBLY (I).)
 - (4) Remove the lower cylinder block. (See 01-10-22 CYLINDER BLOCK DISASSEMBLY (II).)
 - (5) Measure the main journal oil clearance.
 - If it exceeds the maximum specification, replace the main bearing, or grind the main journal and use oversized bearings so that the specified oil clearance is obtained.

Standard main journal oil clearance
0.016—0.039 mm {0.0007—0.0015 in}

Maximum main journal oil clearance
0.084 mm {0.0033 in}

Main bearing size
STD: 2.489—2.510 mm {0.0980—0.0988 in}
OS 0.25: 2.614—2.617 mm {0.10292—0.10303 in}
OS 0.50: 2.739—2.742 mm {0.10784—0.10795 in}

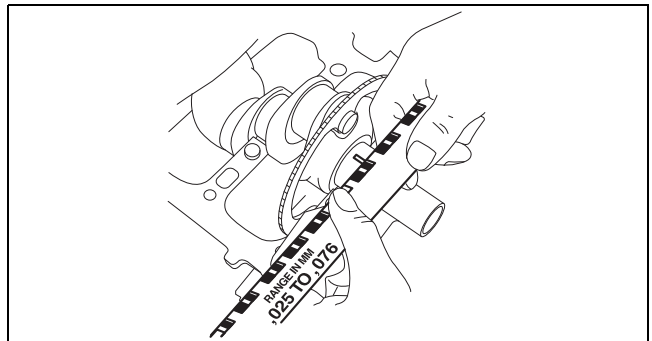

bp31je00000152

BOLT INSPECTION

id011000503300

1. Measure the length of the each bolt.
 - If it exceeds the maximum specification, replace the bolt.

Standard cylinder head bolt length
145.2—145.8 mm {5.717—5.740 in}

Maximum cylinder head bolt length
146.5 mm {5.768 in}

Standard connecting rod bolt length
43.7—44.3 mm {1.73—1.74 in}

Maximum connecting rod bolt length
45.0 mm {1.77 in}

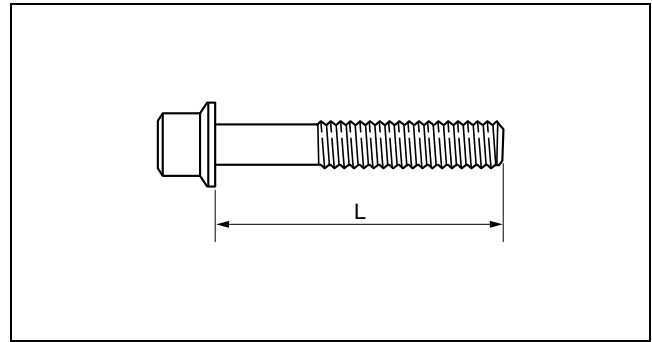

beltze00000026

01-10

CYLINDER BLOCK ASSEMBLY (I)

id011000504000

1. Assemble in the order indicated in the table.

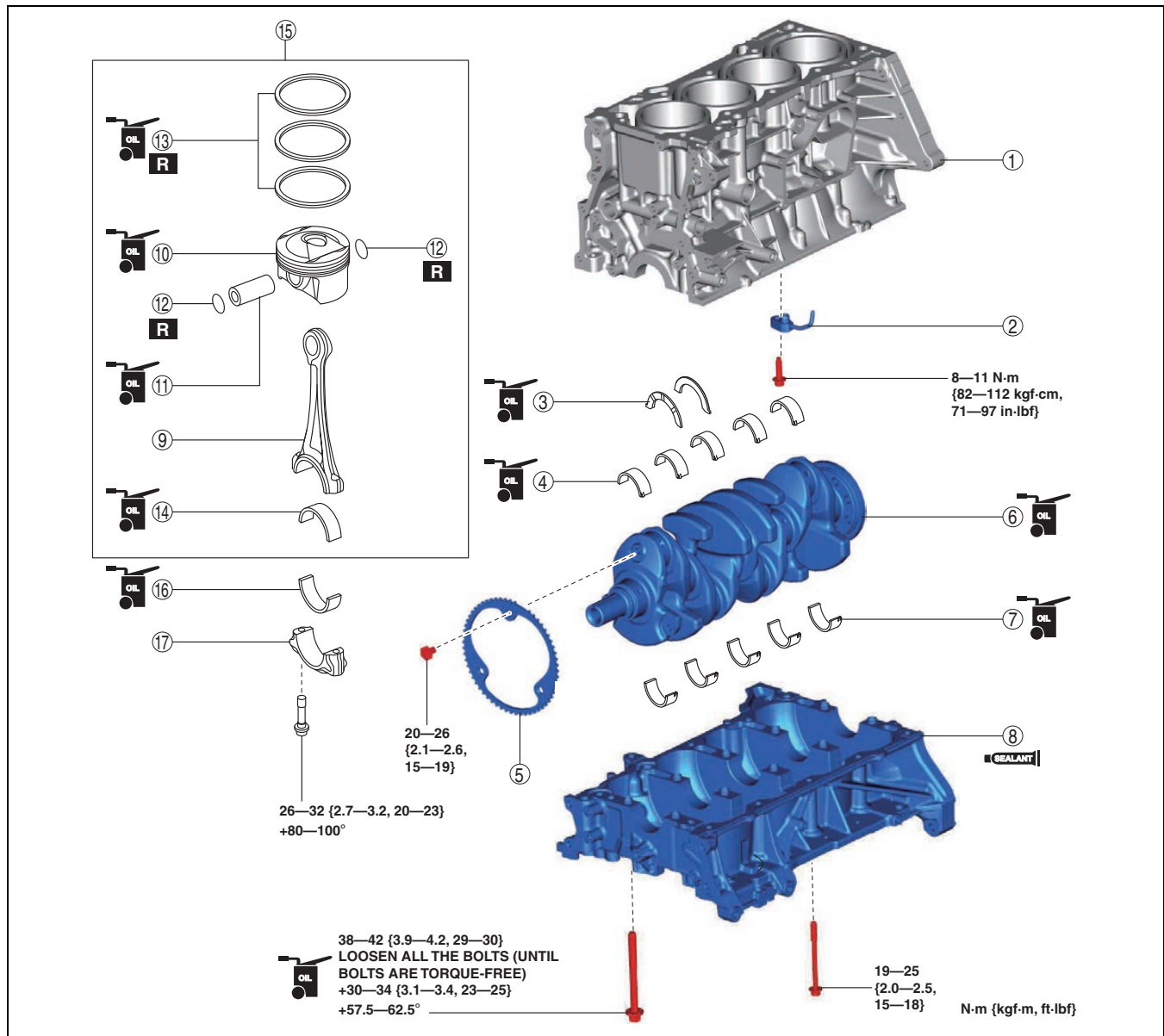

bp25ue00000097

MECHANICAL

1	Upper cylinder block
2	Oil jet valve
3	Thrust bearing (See 01-10-40 Thrust Bearing And Main Bearing Assembly Note.)
4	Upper main bearing (See 01-10-40 Thrust Bearing And Main Bearing Assembly Note.)
5	Plate (See 01-10-41 Plate Assembly Note.)
6	Crankshaft
7	Lower main bearing (See 01-10-40 Thrust Bearing And Main Bearing Assembly Note.)
8	Lower cylinder block (See 01-10-41 Lower Cylinder Block Assembly Note.)
9	Connecting rod

10	Piston
11	Piston pin (See 01-10-43 Piston Pin Assembly Note.)
12	Snap ring (See 01-10-43 Snap Ring Assembly Note.)
13	Piston ring (See 01-10-43 Piston Ring Assembly Note.)
14	Upper connecting rod bearing (See 01-10-44 Connecting Rod Bearing Assembly Note.)
15	Piston, connecting rod (See 01-10-45 Piston, Connecting Rod Assembly Note.)
16	Lower connecting rod bearing (See 01-10-44 Connecting Rod Bearing Assembly Note.)
17	Connecting rod cap (See 01-10-45 Connecting Rod Cap Assembly Note.)

Thrust Bearing And Main Bearing Assembly Note

Caution

- If the thrust bearings and main bearings are reused, assemble the bearings to the same positions and in the direction as before removal to prevent engine damage due to seizure or burning of the bearing.
- To prevent engine damage due to seizure or burning of the bearing, apply engine oil to the sliding part when assembling.

Thrust bearing

1. Apply clean engine oil to the thrust bearings.
2. Assemble the bearings with the oil groove of the thrust bearing pointed toward the sliding surface.

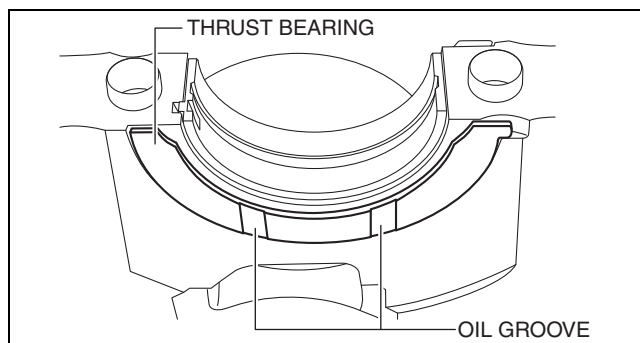

bpe5ue0000016

Main bearing

1. Apply clean engine oil to the main bearings.
2. Align the positioning tab of the main bearing with the positioning groove of the lower and upper cylinder block, and assemble the bearings.

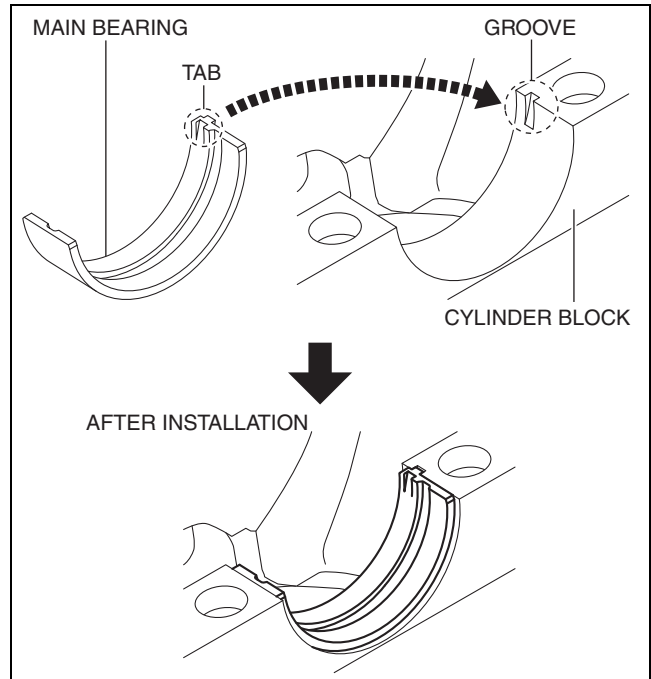

bpe5ue0000017

01-10

Plate Assembly Note

Caution

- **Placing the crankshaft on a disassembly bench will deform or damage it because the plate for the crankshaft position sensor signal detection installed to the crankshaft is larger than the counterweight. Therefore, set wood blocks or similar objects on the both sides of the crankshaft so that the plate does not contact the disassembly bench directly when placing the crankshaft on it bench.**

1. Install the plate using the following procedure:
 - (1) Install the groove of the plate tooth to the position shown in the figure and temporarily tighten bolt A.
 - (2) Temporarily tighten the bolt B.
 - (3) Install bolt C and tighten the bolts to the specified tightening torque in the order of C, B, and A.

Tightening torque

20—26 N·m {2.1—2.6 kgf·m, 15—19 ft·lbf}

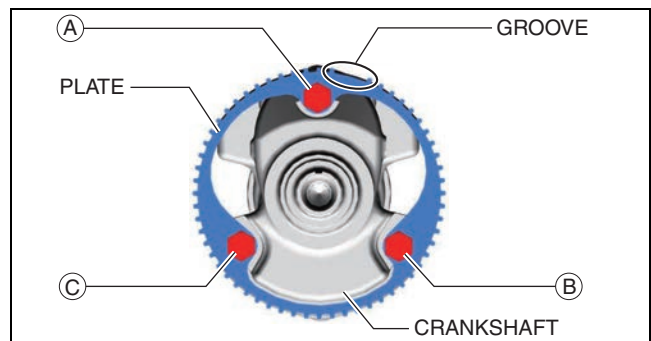

bp25ue0000088

MECHANICAL

Lower Cylinder Block Assembly Note

1. Completely clean and remove any oil, dirt, sealant or other foreign matter that may be adhering to the lower cylinder block and cylinder block.
2. When reusing the lower cylinder block installation bolts, clean any old sealant from the bolts.

Caution

- Apply silicon sealant in a single, unbroken line.
- To prevent silicon sealant from hardening, adhere the engine front cover and the cylinder block firmly within 10 min. after applying silicon sealant. After adhering them, tighten the installation bolts immediately.
- Using bolts with the old seal adhering could cause cracks in the cylinder block.

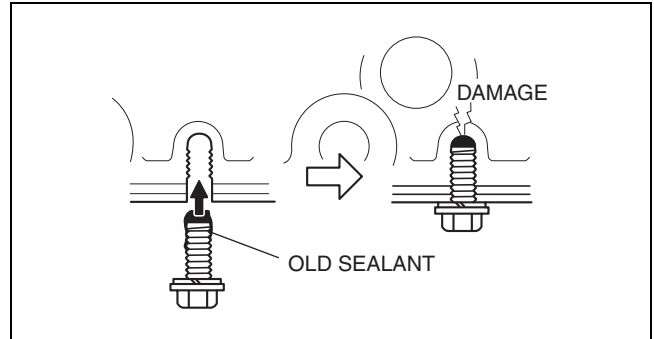

bpe5ue0000019

3. Apply silicon sealant to the lower cylinder block shown in the figure.

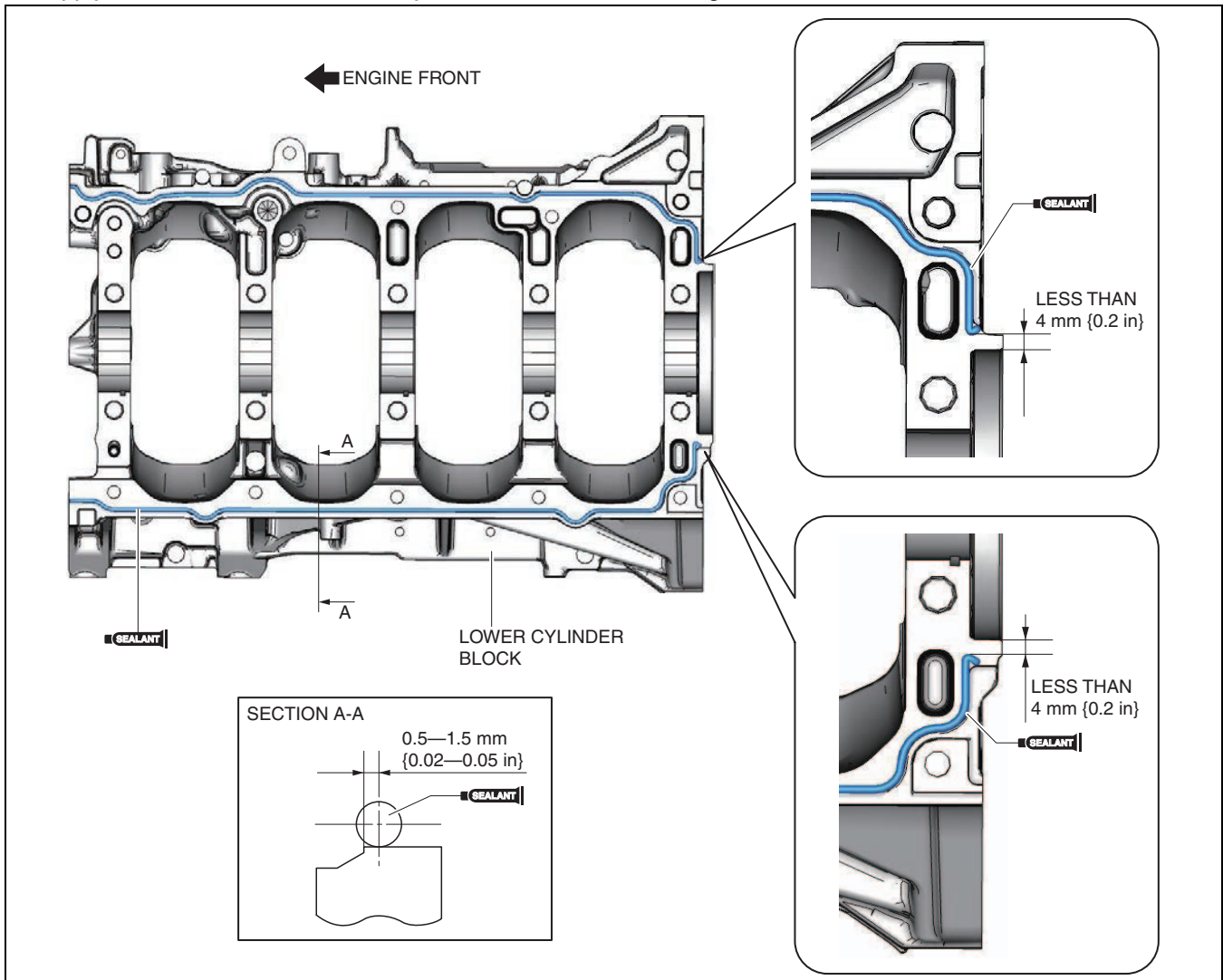

bp25ue0000020

Bead thickness

2—6 mm {0.1—0.2 in}

4. Install the lower cylinder block.
5. Tighten the lower cylinder block installation bolts using the following procedure:
 - (1) Apply clean engine oil to the seating surface and thread of lower cylinder block installation bolts A.
 - (2) Tighten lower cylinder block installation bolts A in the order shown in the figure using the following procedure:

Tightening procedure

Step 1: 38—42 N·m {3.9—4.2 kgf·m, 29—30 ft·lbf}

Step 2: Loosen all the bolts (until bolts are torque-free).

Step 3: 30—34 N·m {3.1—3.4 kgf·m, 23—25 ft·lbf}

Step 4: 57.5—62.5°

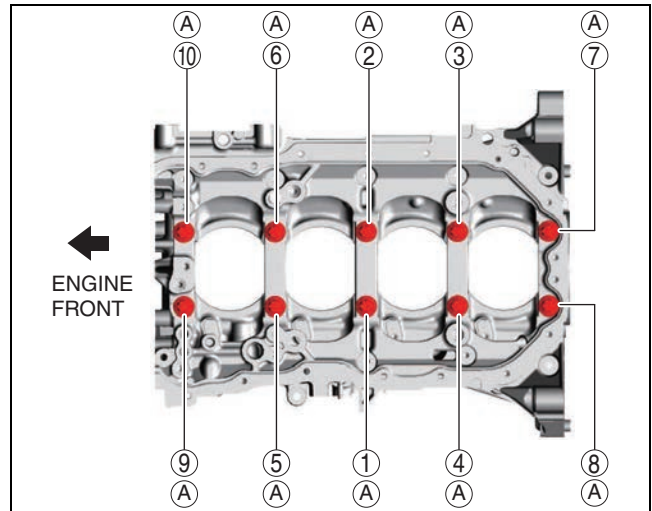

bp25ue0000021

- (3) Tighten the lower cylinder block installation bolts B in the order shown in the figure.

Tightening torque

19—25 N·m {2.0—2.5 kgf·m, 15—18 ft·lbf}

6. After verifying that silicone sealant protrudes to the rear oil seal press-in part, wipe away the excess silicone sealant.
 - If silicone sealant does not protrude to the rear oil seal press-in part, remove the lower cylinder block and apply silicone sealant again.

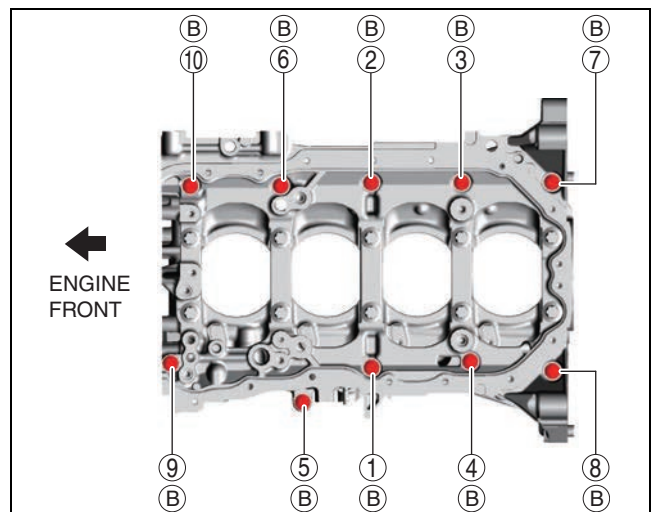

bp25ue0000022

Piston Pin Assembly Note

1. Apply clean engine oil to the piston pin.
2. Insert the piston pin to the piston and connecting rod.

Note

- When assembling the piston to the connecting rod, each one can be assembled in either direction.

Snap Ring Assembly Note

Caution

- Do not compress the outer diameter of the snap ring more than necessary when assembling the snap ring (22.23 mm {0.8752 in} or less).

1. Insert a new snap ring using a thin plier.

MECHANICAL

Piston Ring Assembly Note

Note

- It is not required to position the end gap between the top ring and second ring.

- Assemble the oil ring so that the end gap of each oil ring rail does not overlap as shown in the figure.

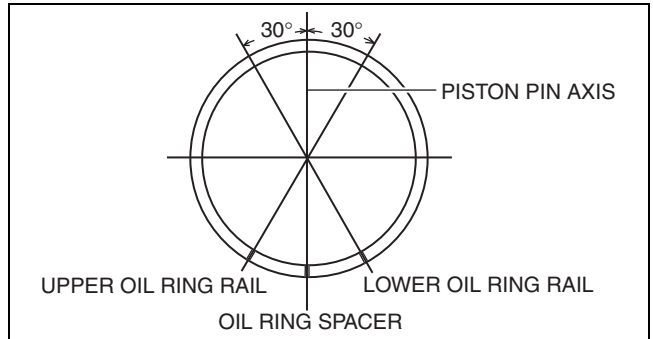

bpe5ue0000022

- Assemble so that the identification paint marks on the top and second rings are visible to the right side of each end gap.

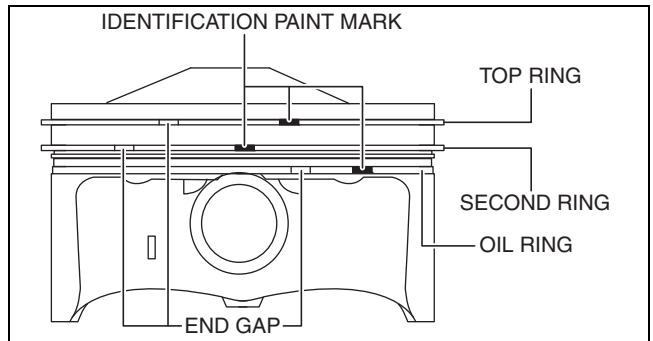

bp25ue0000089

Note

- If there are no identification paint marks, assemble the rings as follows:

Top ring

- Assemble the ring with the notch (large side) on the inner circumference of the ring at the top.

Second ring

- Assemble the ring with the notch on the outer circumference of the ring pointing downward.

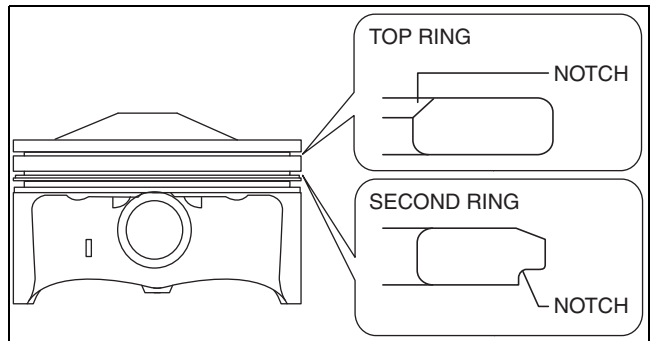

bpe5ue0000024

Connecting Rod Bearing Assembly Note

Caution

- If a connecting rod bearing is reused, assemble it to the same position and in the direction as before removal to prevent engine damage due to seizure or burning of the bearing.
- To prevent engine damage due to seizure or burning of the bearing, apply engine oil to the sliding part when assembling.

1. Apply engine oil to the connecting rod bearings.
2. Align the positioning tab of the connecting rod bearing with the positioning groove of the connecting rod and connecting rod cap, and assemble the bearings.

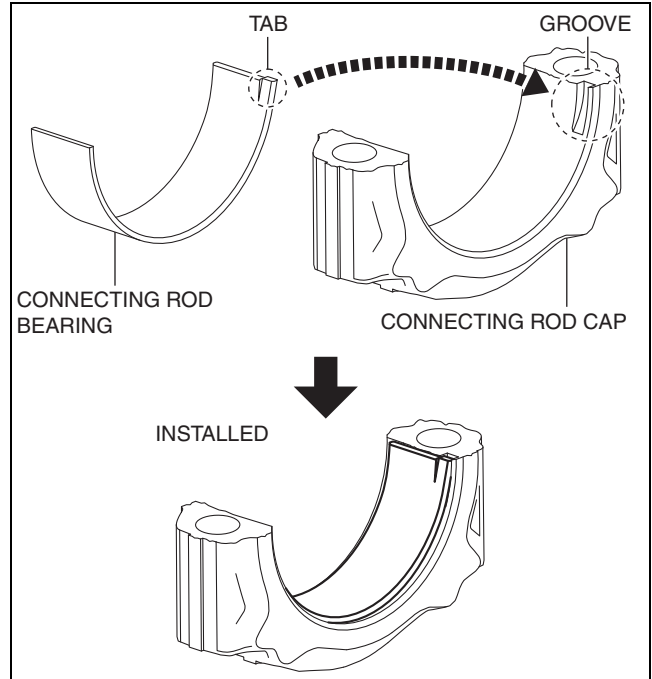

bp25ue0000090

Piston, Connecting Rod Assembly Note

1. Insert the piston into the cylinder with the mark on top of the piston facing the intake side.

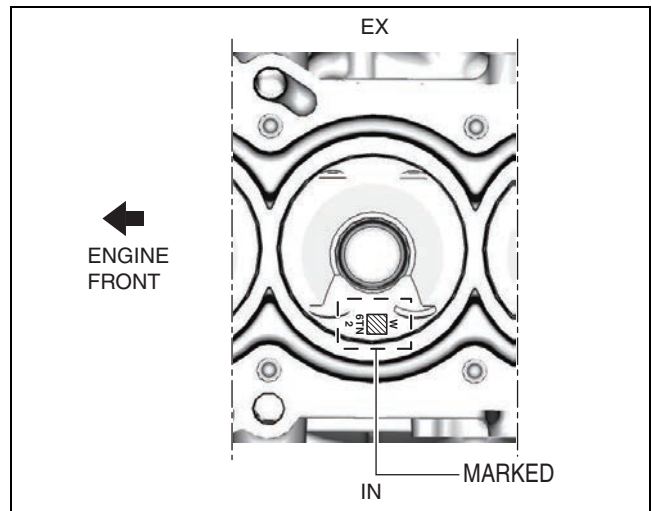

bp25ue0000023

Connecting Rod Cap Assembly Note

Caution

- When assembling the connecting rod caps, align the broken, rough faces of the connecting rods and connecting rod caps.
- If the following condition is met, replace the connecting rod cap bolts.
 - Length exceeds maximum specification

Standard connecting rod cap bolt length
43.7—44.3 mm {1.73—1.74 in}

Maximum connecting rod cap bolt length
45.0 mm {1.77 in}

1. Position so that the broken, rough faces of the connecting rods and connecting rod caps are aligned exactly, and assemble the connecting rod caps.
2. Tighten the connecting rod cap bolts in the following two steps.

Tightening procedure

Step 1: 26—32 N·m {2.7—3.2 kgf·m, 20—23 ft·lbf}

Step 2: 80—100°

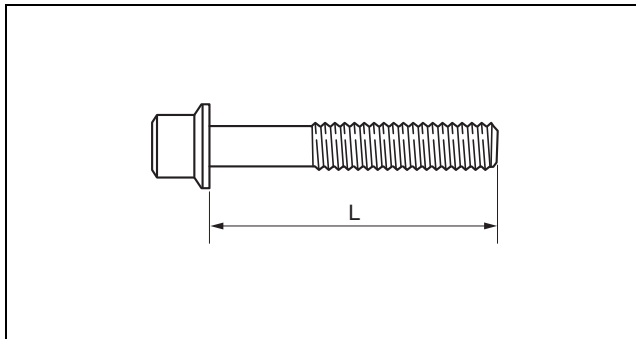

bpe5ue0000027

CYLINDER BLOCK ASSEMBLY (II)

id011000504100

Special Service Tool (SST)

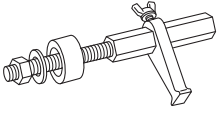
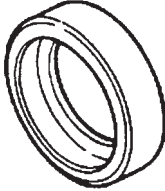
1. : Mazda SST number		2. : Global SST number	
1: 49 E011 1A0	1: 49 S033 101	2: -	2: -
Ring gear brake set	Dust cover installer		

01-10

1. Assemble in the order indicated in the table.

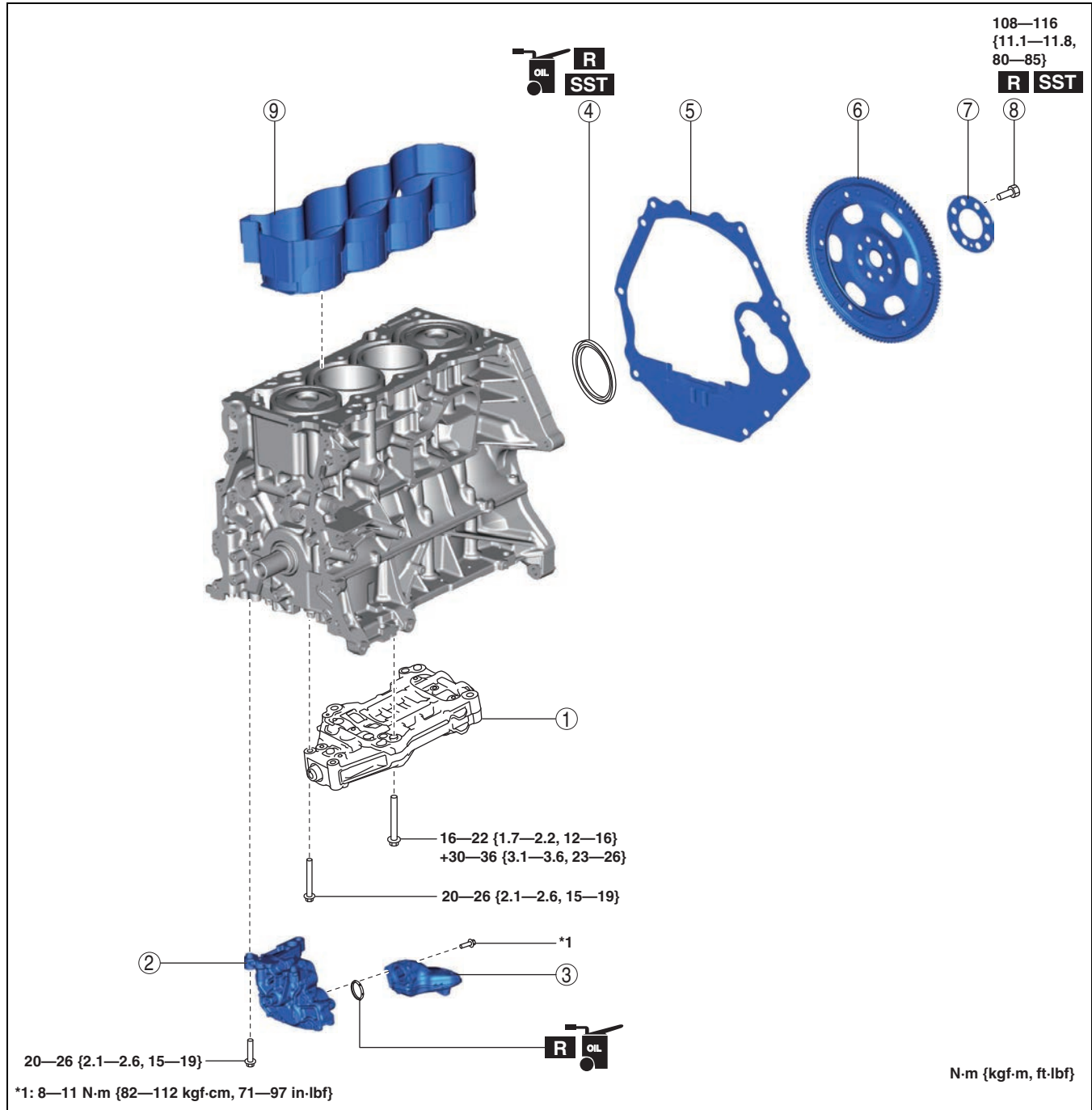

bp25ue0000024

MECHANICAL

1	Balancer unit (See 01-10-47 Balancer Unit Assembly Note.)
2	Oil pump (See 01-10-48 Oil Pump Assembly Note.)
3	Oil strainer
4	Rear oil seal (See 01-10-49 Rear Oil Seal Assembly Note.)

5	End plate (See 01-10-51 End Plate Assembly Note.)
6	Drive plate
7	Backing plate
8	Drive plate installation bolt (See 01-10-51 Drive Plate Installation Bolt Assembly Note.)
9	Water jacket spacer

Balancer Unit Assembly Note

- Assemble the balancer unit using the following procedure:
 (1) Tighten the bolts in the order shown in the figure.

Tightening torque

Installation position	Tightening torque
1—4	16—22 N·m {1.7—2.2 kgf·m, 12—16 ft·lbf}
5, 6	20—26 N·m {2.1—2.6 kgf·m, 15—19 ft·lbf}

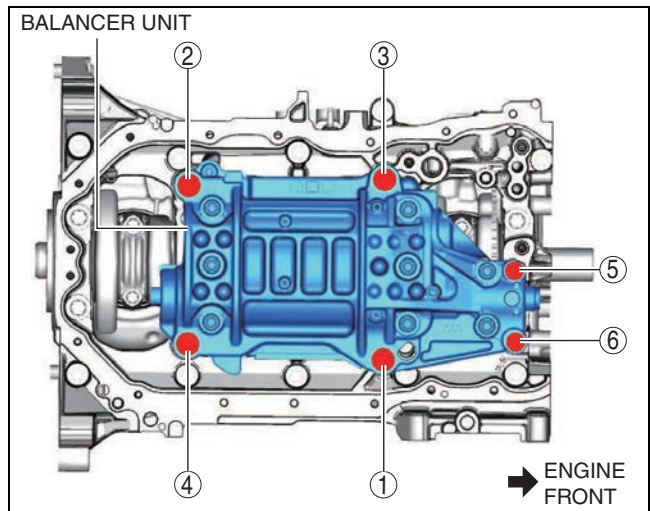

bp25ue0000025

- Retighten the bolts in the order of the numbers indicated in the figure.

Tightening torque

30—36 N·m {3.1—3.6 kgf·m, 23—26 ft·lbf}

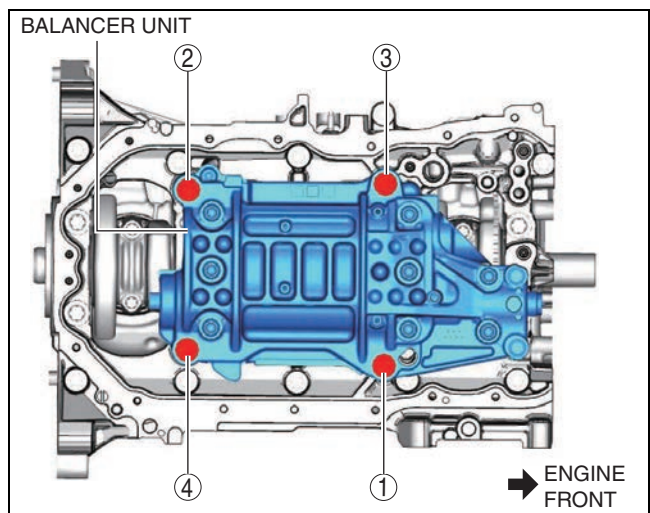

bp25ue0000026

Oil Pump Assembly Note

1. Install the oil pump using the following procedure:

- (1) Temporarily tighten the **three bolts** shown in the figure.

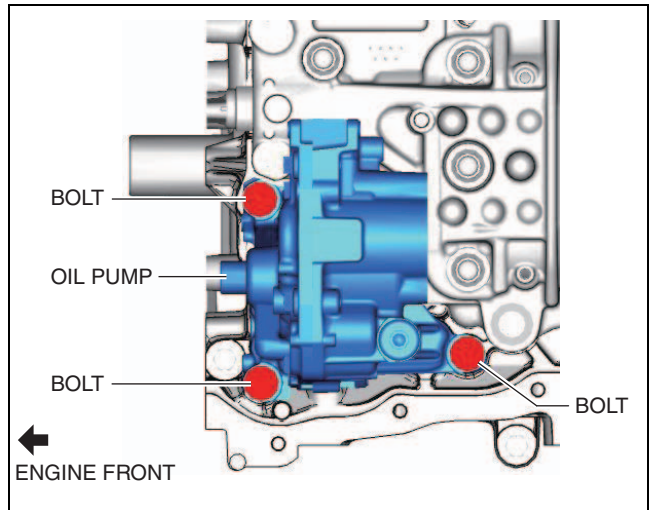

bp25ue0000027

01-10

- (2) Tighten the **two bolts** shown in the figure to the specified torque.

Note

- The tightening order for the two bolts is optional.

Tightening torque

20—26 N·m {2.1—2.6 kgf·m, 15—19 ft·lbf}

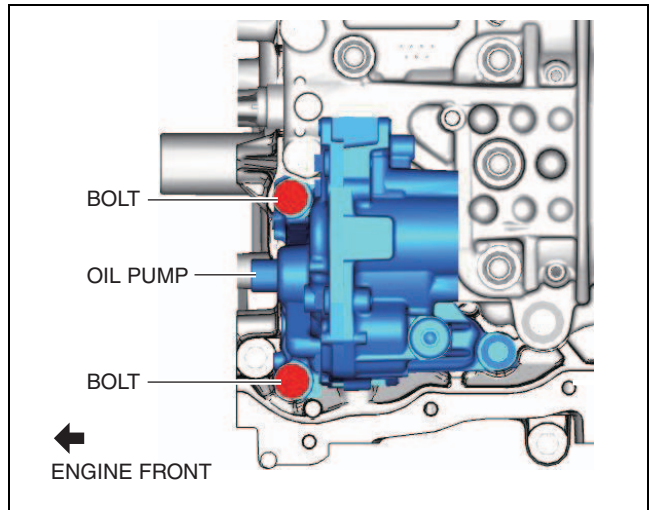

bp25ue0000028

- (3) Finally, tighten the bolt shown in the figure to the specified torque.

Tightening torque

20—26 N·m {2.1—2.6 kgf·m, 15—19 ft·lbf}

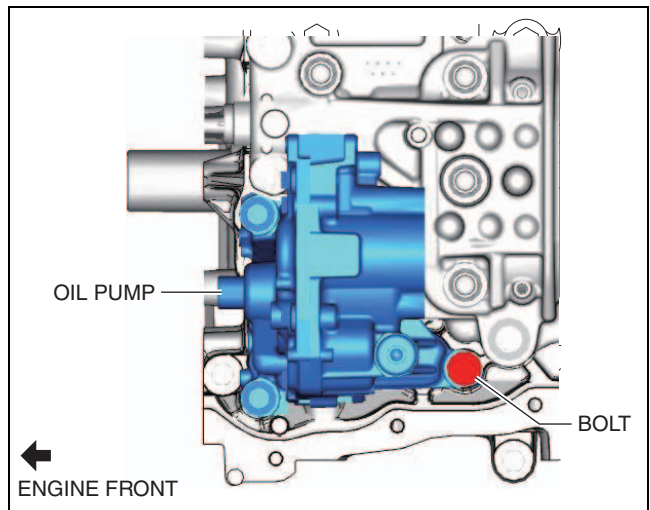

bp25ue0000029

MECHANICAL

Rear Oil Seal Assembly Note

1. Apply clean engine oil to the inner surface of a new rear oil seal.
2. Insert the rear oil seal into the cylinder block by hand.
3. Tap the oil seal in evenly using the **SST** and a hammer.

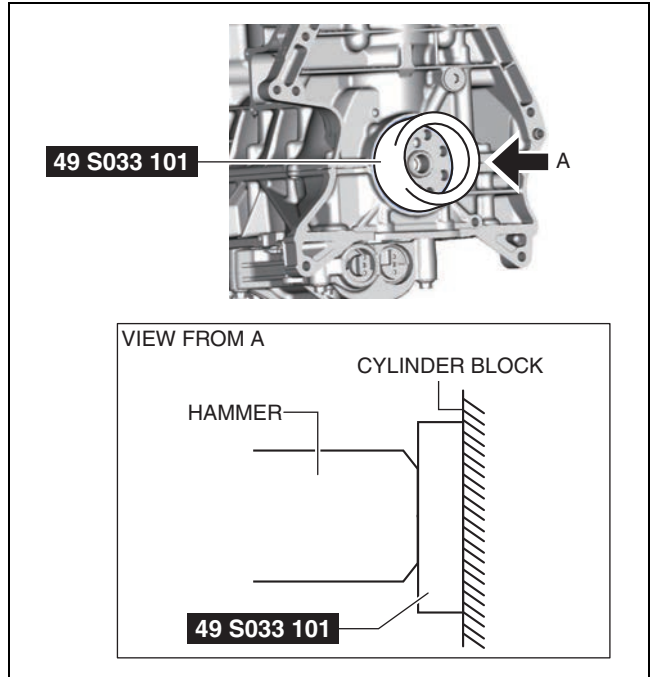

bp25ue0000030

Rear oil seal press on amount
0—0.5 mm {0—0.019 in}

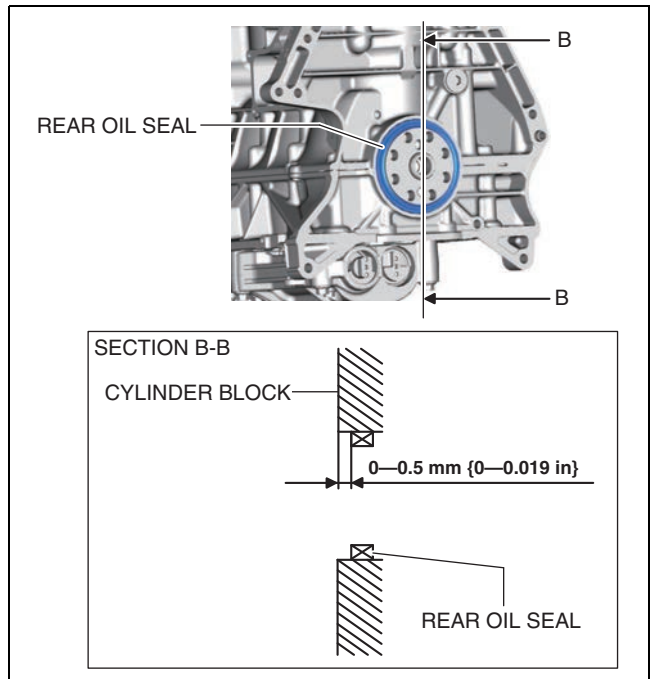

bp25ue0000031

MECHANICAL

End Plate Assembly Note

1. After end plate assembly, crimp the parts A and B shown in the figure.

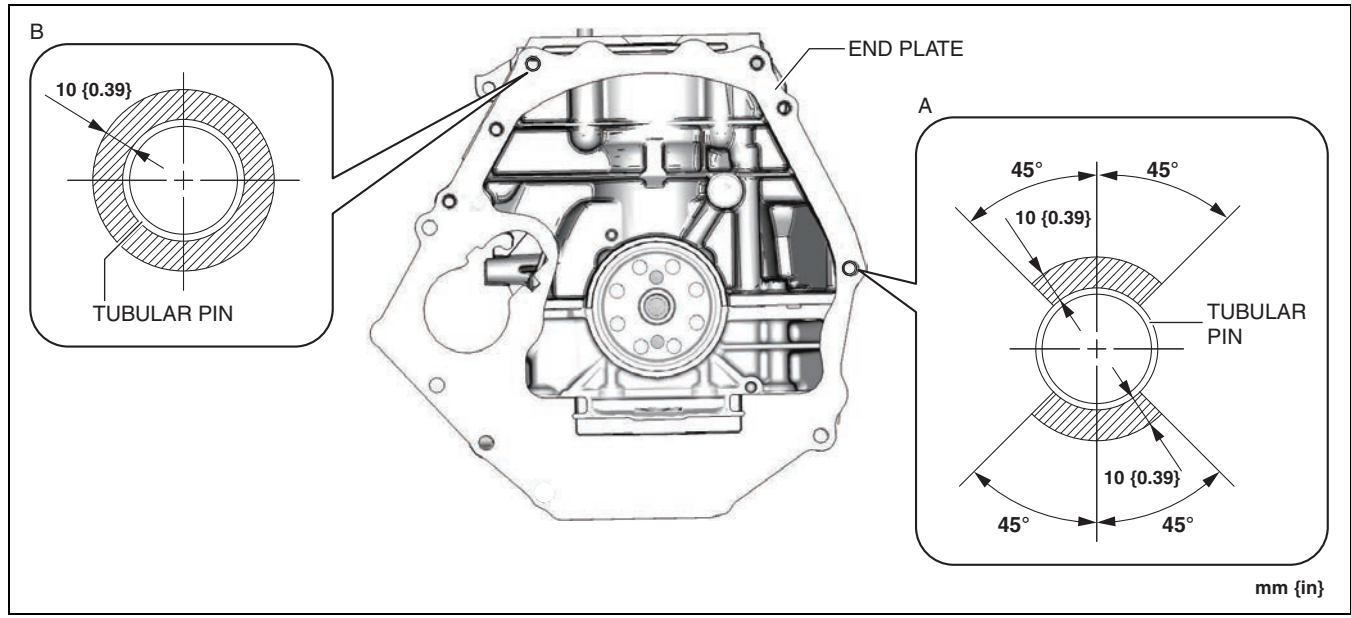

01-10

Crimp procedure

Crimp depth: 0.1—1.0 mm {0.004—0.039 in}

Crimp width: 0.5—10.0 mm {0.02—0.39 in}

Crimp locations: Part A is 1 or more on one-side within shaded area and part B is 2 or more within shaded areas

2. After crimping, verify that there is no damage and removal of the end plate.

Drive Plate Installation Bolt Assembly Note

1. Hold the crankshaft using the **SST**.
2. Tighten the new bolts in two or three passes in the order shown in the figure.

Tightening torque

108—116 N·m {11.1—11.8 kgf·m, 80—85 ft·lbf}

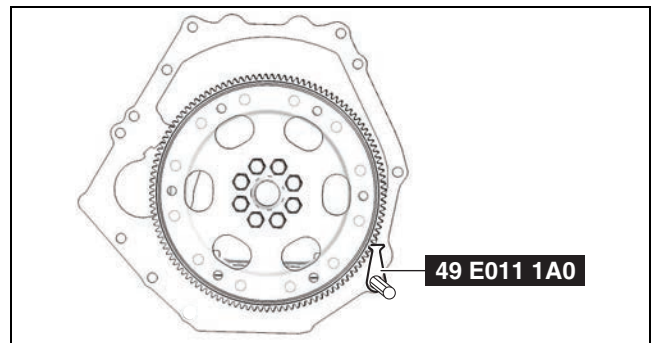



bp25ue0000092

MECHANICAL

CYLINDER HEAD ASSEMBLY (I)

id011000504300

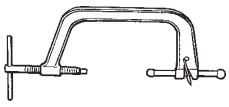
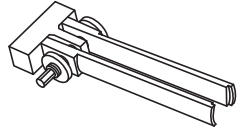
Special Service Tool (SST)

1. : Mazda SST number 2. : Global SST number					
1: 49 0636 100B 2: - Valve spring lifter arm		1: 49 B012 0A2A 2: - Pivot		1: 49 B012 016 2: - Attachment	

1. Assemble in the order indicated in the table.

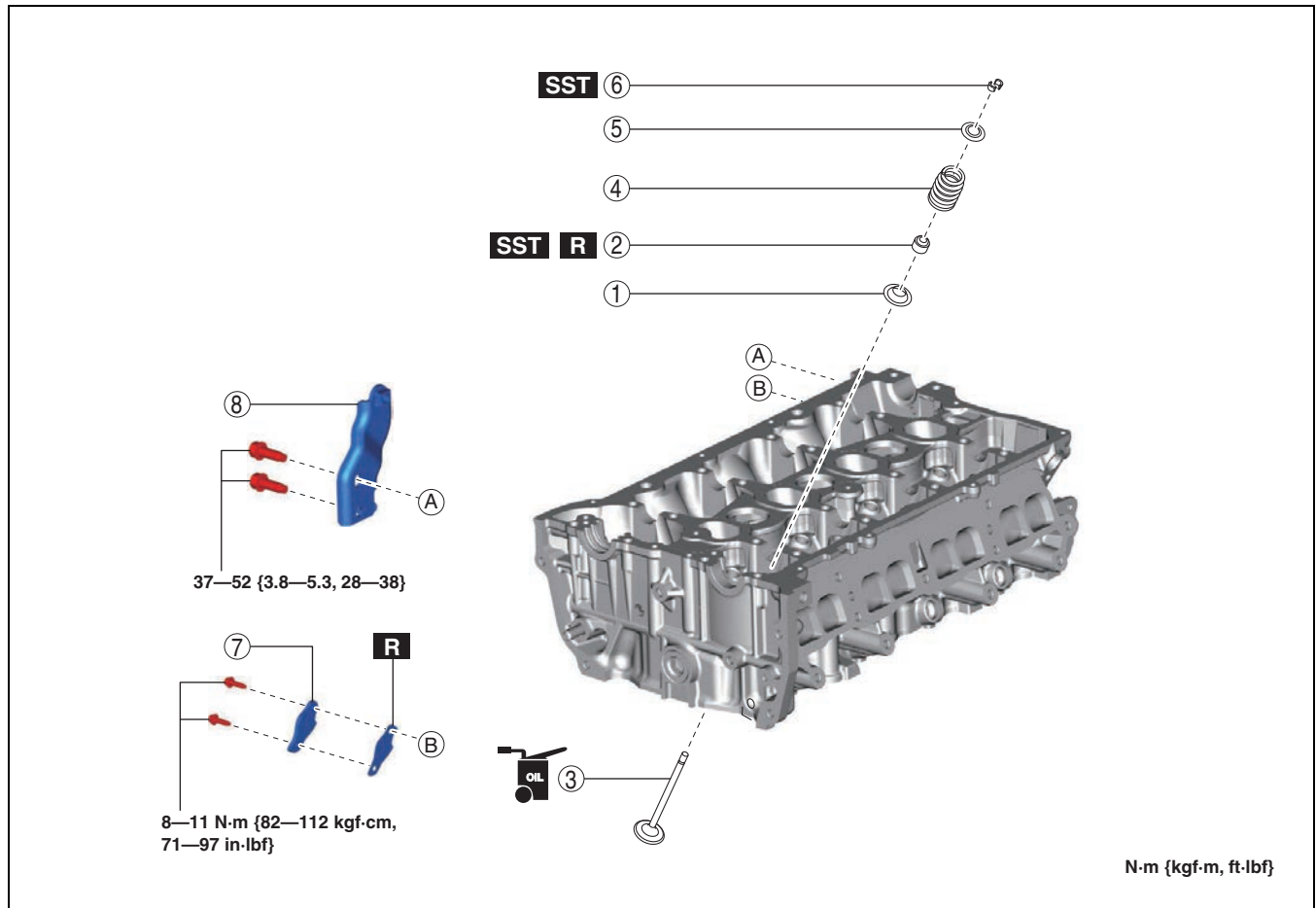

1	Lower valve spring seat
2	Valve seal (See 01-10-53 Valve Seal Assembly Note.)
3	Valve
4	Valve spring (See 01-10-53 Valve Spring Assembly Note.)

5	Upper valve spring seat
6	Valve keeper (See 01-10-54 Valve Keeper Assembly Note.)
7	Blind cover (See 01-10-54 Blind cover Assembly Note.)
8	Hanger bracket

Valve Seal Assembly Note

1. Press on the valve seal to the valve guide using the **SST** by hand.

Valve seal identification color

IN: GREEN

EX: GRAY

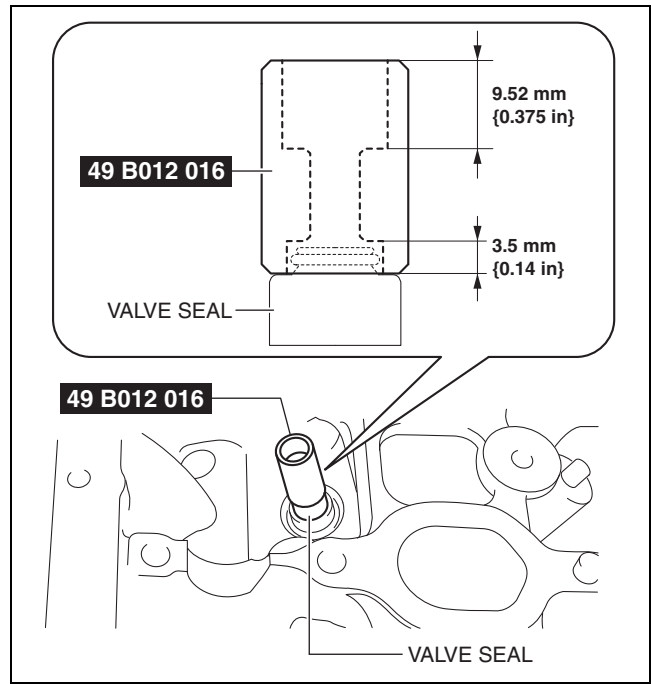

bpe5ue0000043

01-10

Valve Spring Assembly Note

Caution

- The valve springs differ depending on IN and EX sides. Therefore, verify the free length or identification paint beforehand and assemble the valve springs correctly.

1. Assemble the valve spring with the small diameter side of the valve spring facing upward.

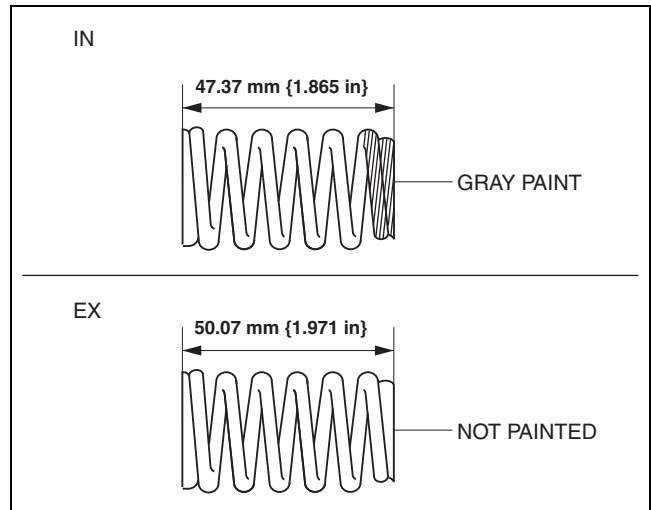

bp25ue0000035

MECHANICAL

Valve Keeper Assembly Note

1. Install the valve keeper using the SST.

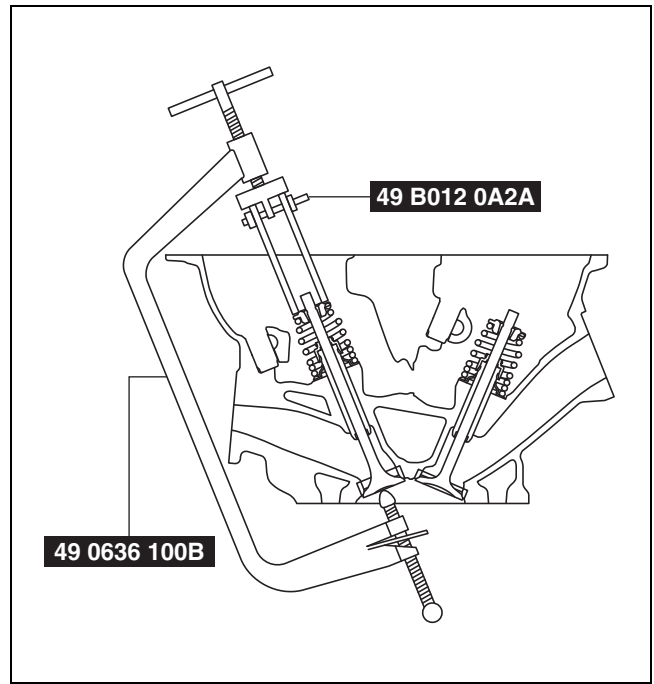

bpe1ze0000020

Blind cover Assembly Note

1. Assemble the new gasket so that the identification tab is on the rear side of the engine and the painted surface is facing the cylinder head side.
2. Assemble the blind cover so that the arrow is facing the upper surface of the cylinder head.

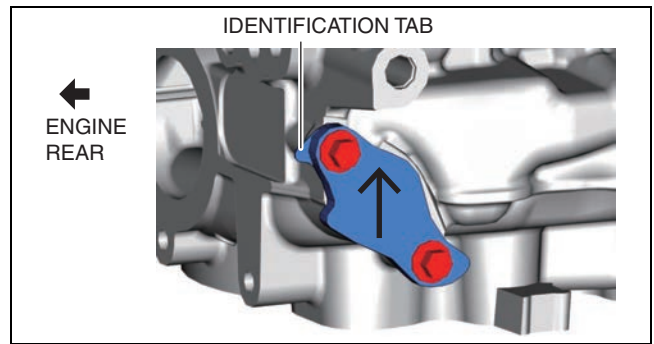

bp25ue0000081

Caution

- If the camshaft is rotated with the timing chain removed and the piston at the top dead center position, the valve may contact the piston and the engine could be damaged. When rotating the camshaft with the timing chain removed, rotate it after lowering the piston from the top dead center position.
- When rotating the camshaft using a wrench on the cast hexagon, the wrench may contact the rocker arm and damage the rocker arm. To prevent damage to the rocker arm when holding the camshaft on the cast hexagon, use a wrench on the rear side of the engine as shown in the figure to secure a clearance between the cam.
- Carefully assemble the HLA because the specification is different between the intake side and the exhaust side.

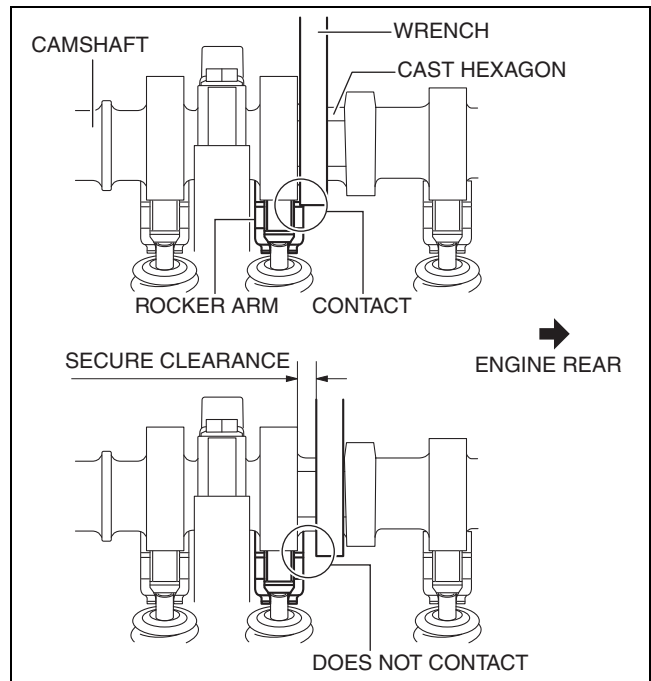

am3uuw0000896

Note

- Width at the cast hexagon of the camshaft is 22—24 mm {0.87—0.94 in}.

1. Assemble in the order indicated in the table.

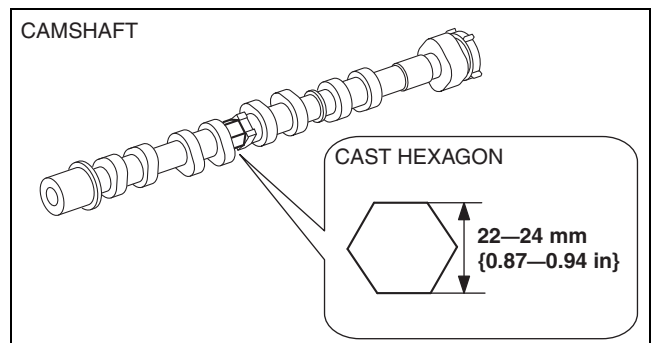

bpe5ue00000047

MECHANICAL

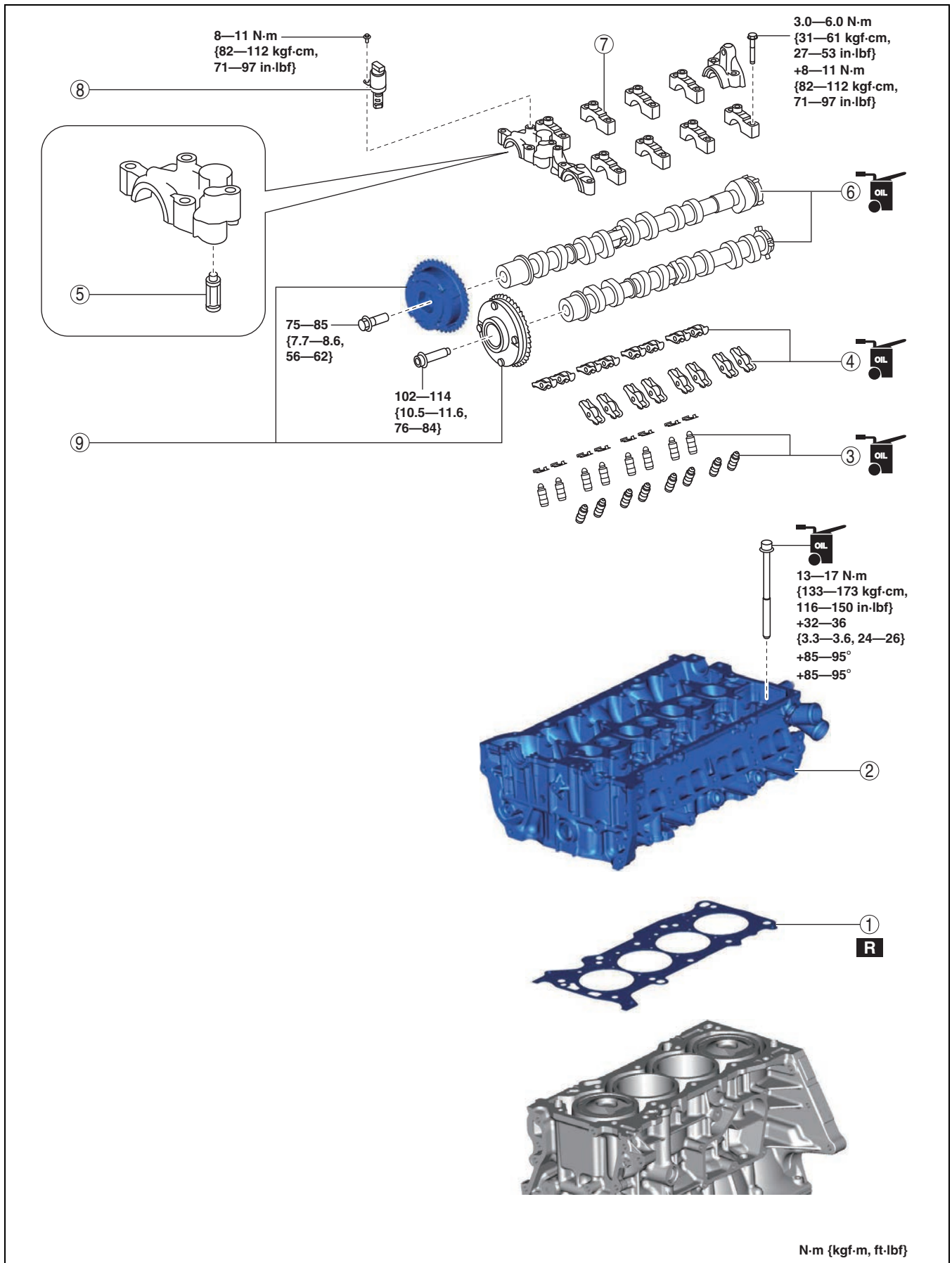

bp25ue0000098

MECHANICAL

1	Cylinder head gasket
2	Cylinder head (See 01-10-57 Cylinder Head Assembly Note.)
3	HLA (See 01-10-57 HLA Assembly Note.)
4	Rocker arm (See 01-10-59 Rocker Arm Assembly Note.)
5	OCV oil filter

6	Camshaft (See 01-10-59 Camshaft Assembly Note.)
7	Camshaft cap (See 01-10-59 Camshaft Assembly Note.)
8	OCV
9	Electric variable valve timing actuator, hydraulic variable valve timing actuator (See 01-10-62 Electric Variable Valve Timing Actuator, Hydraulic Variable Valve Timing Actuator Assembly Note.)

01-10

Cylinder Head Assembly Note

Caution

- If the following condition is met, replace the cylinder head bolts.

- Length exceeds maximum specification

Standard cylinder head bolt length L
145.2—145.8 mm {5.717—5.740 in}

Maximum cylinder head bolt length L
146.5 mm {5.767 in}

1. When a cylinder head bolt is reused, apply engine oil to any part of the following:
 - Bolt seating surface
 - Cylinder head seating surface
2. Tighten the cylinder head bolts in the order shown in the following four steps.

Tightening procedure

Step 1: 13—17 N·m {133—173 kgf·cm, 116—150 in·lbf}

Step 2: 32—36 N·m {3.3—3.6 kgf·m, 24—26 ft·lbf}

Step 3: 85—95°

Step 4: 85—95°

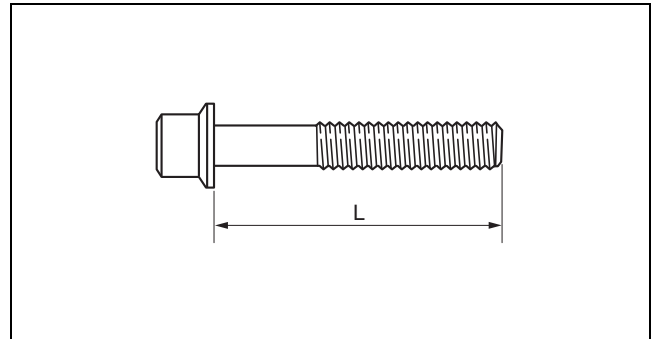

adejiw00001214

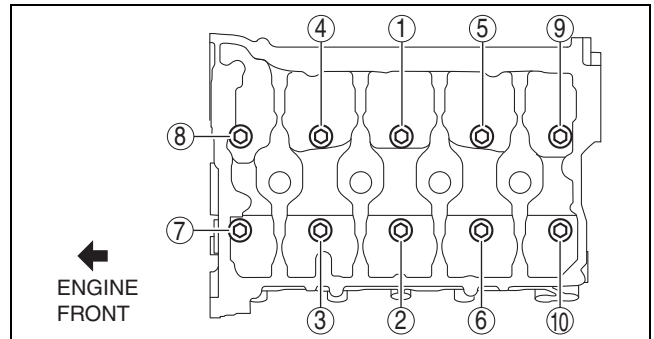

am3uuw0000881

MECHANICAL

HLA Assembly Note

1. Perform HLA air bleeding using the following procedure:
 - (1) Put the HLA in a container filled with engine oil.

Caution

- Do not insert the round bar firmly because the check ball spring force is extremely weak.

- (2) While lightly pressing the check ball using a round bar (**approx. 1.0 mm {0.039 in}** diameter), bleed air by moving the plunger up and down.
 - (3) Press the end of the plunger in the oil and verify that there is no rebounding feel.
 - If rebounding feel cannot be eliminated, replace the HLA.
2. Install the HLAs to their original positions as before removal. (intake side)
 3. Apply engine oil to the HLAs surface where it contacts the rocker arms. (exhaust side)

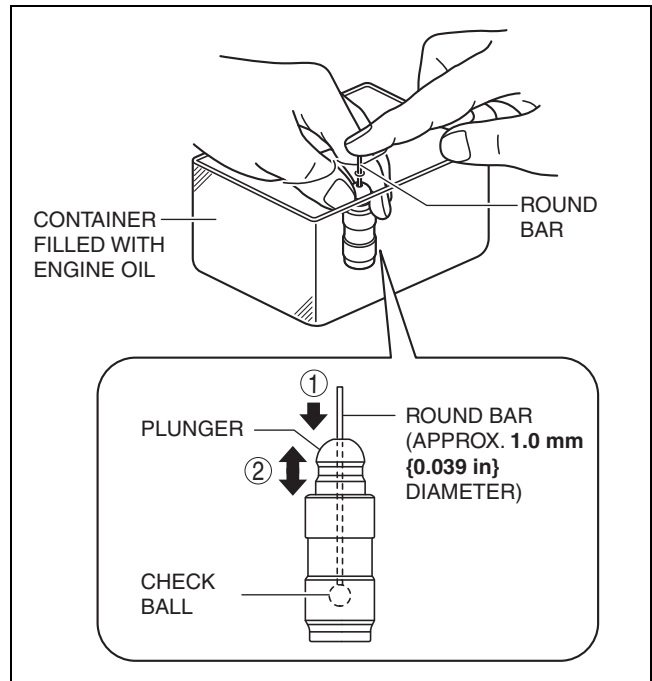

bpe5ue0000048

4. Assemble the HLAs using the following procedure: (exhaust side)
 - (1) Press the clip onto the rocker arm.
 - (2) Insert the HLA from the underside of the clip.

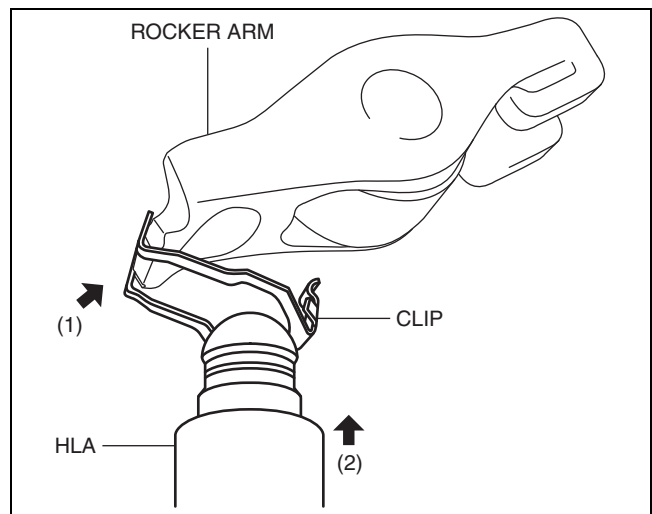

bp25ue0000037

- (3) Press the clip in the direction of the arrow and install it to the rocker arm.

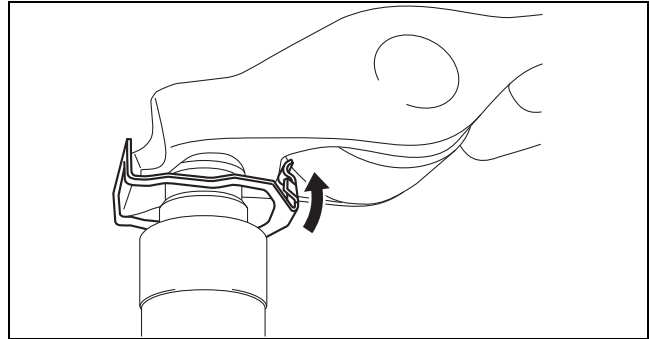

bp25ue00000038

- (4) Verify that the tab of the clip is securely engaged to the rocker arm.

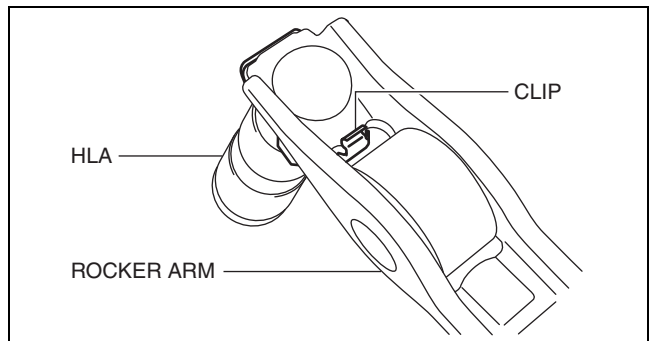

bp25ue00000039

Rocker Arm Assembly Note

1. Apply engine oil to the HLAs and the end of the valve stems.
2. Install the rocker arms to their original positions as before removal. (intake side)
3. Install the rocker arms, clips and HLAs as a single unit to the same positions as before removal. (exhaust side)

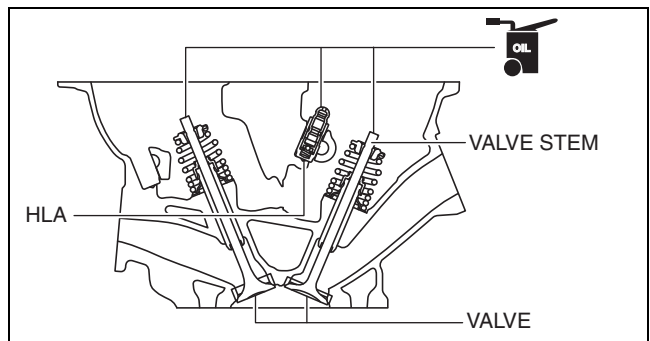

bp25ue00000040

MECHANICAL

Camshaft Assembly Note

1. Apply SAE 90 gear oil or equivalent, or engine oil to the positions shown in the figure.

Caution

- Apply 0.05 ml {0.05 cc, 0.003 in³} or less of oil to area A in the figure.

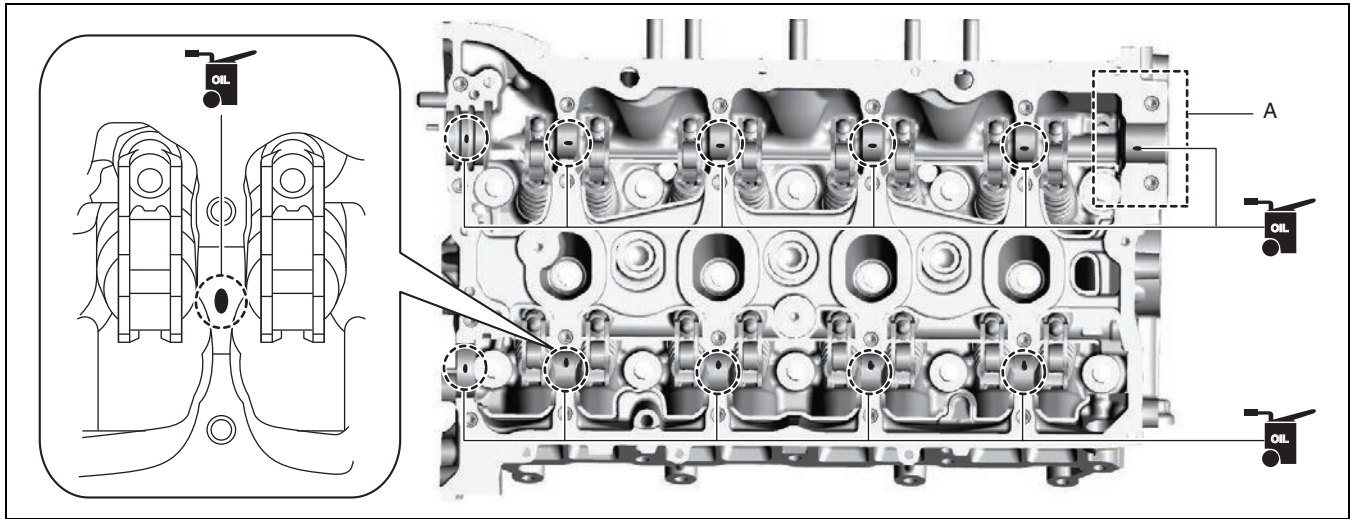

bp25ue0000041

2. Apply SAE 90 gear oil or equivalent, or engine oil to the following locations of each camshaft.
 - Thrust surface of front journal (both surfaces front and back)

Note

- If oil is applied to the front camshaft cap, oil should not be applied to the thrust surface of the front journal.

3. As shown in the figure, align the cam position of cylinder No.1 around top dead center (TDC) and place the camshafts on the cylinder head.

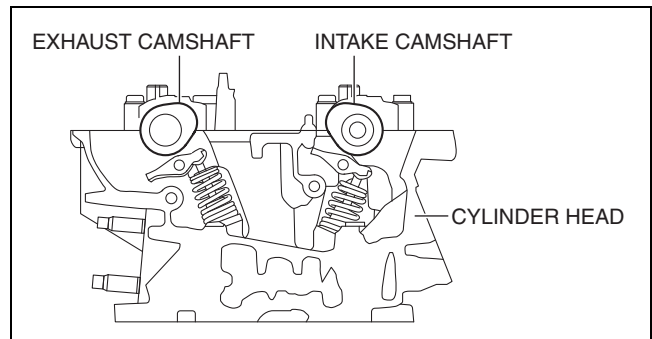

bpe2ue0000070

4. Apply SAE 90 gear oil or equivalent, or engine oil to the central area of each journal on the camshaft.

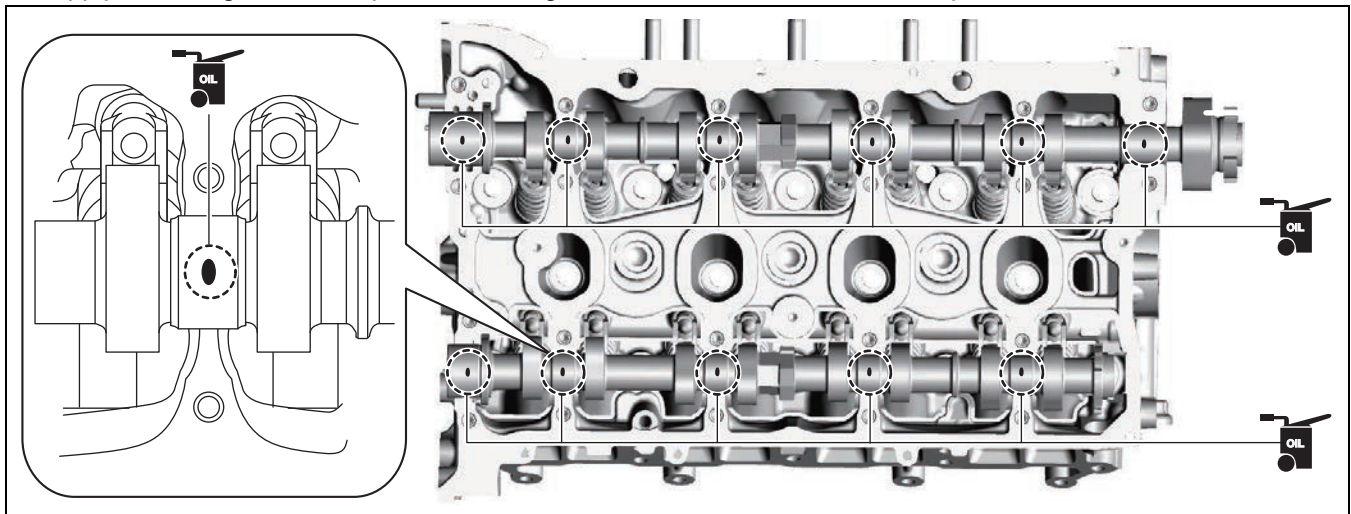

bp25ue0000042

MECHANICAL

- Apply SAE 90 gear oil or equivalent, or engine oil to the thrust surface of the front camshaft cap.
 - If oil is applied to the front journal thrust surface of each camshaft, oil should not be applied to the front camshaft cap.
- Apply sealant (Loctite #962T or equivalent) to the rear camshaft cap installation area on the exhaust side or the rear camshaft caps on the exhaust side of the cylinder head.

Note

- To prevent engine oil leakage, apply sealant to the rear camshaft cap installation area on the exhaust side or the rear camshaft caps on the exhaust side of the cylinder head, and seal the journal.

Caution

- Do not spill sealant on the journal.

Sealant bead width

1—3 mm {0.04—0.11 in}

- Install the camshaft caps in the marked number order, and temporarily tighten the camshaft cap installation bolts in two or three passes evenly.

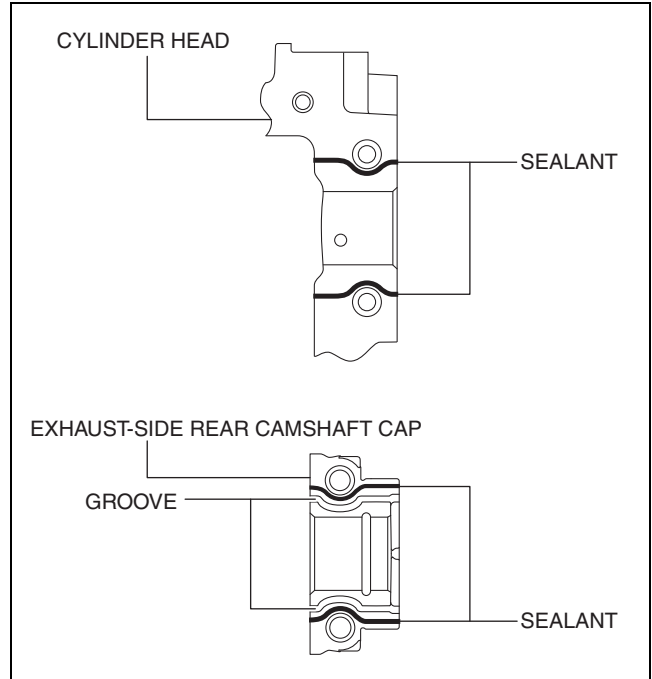

am2zzw0001119

- Tighten the camshaft cap installation bolts in two steps in the order shown in the figure.

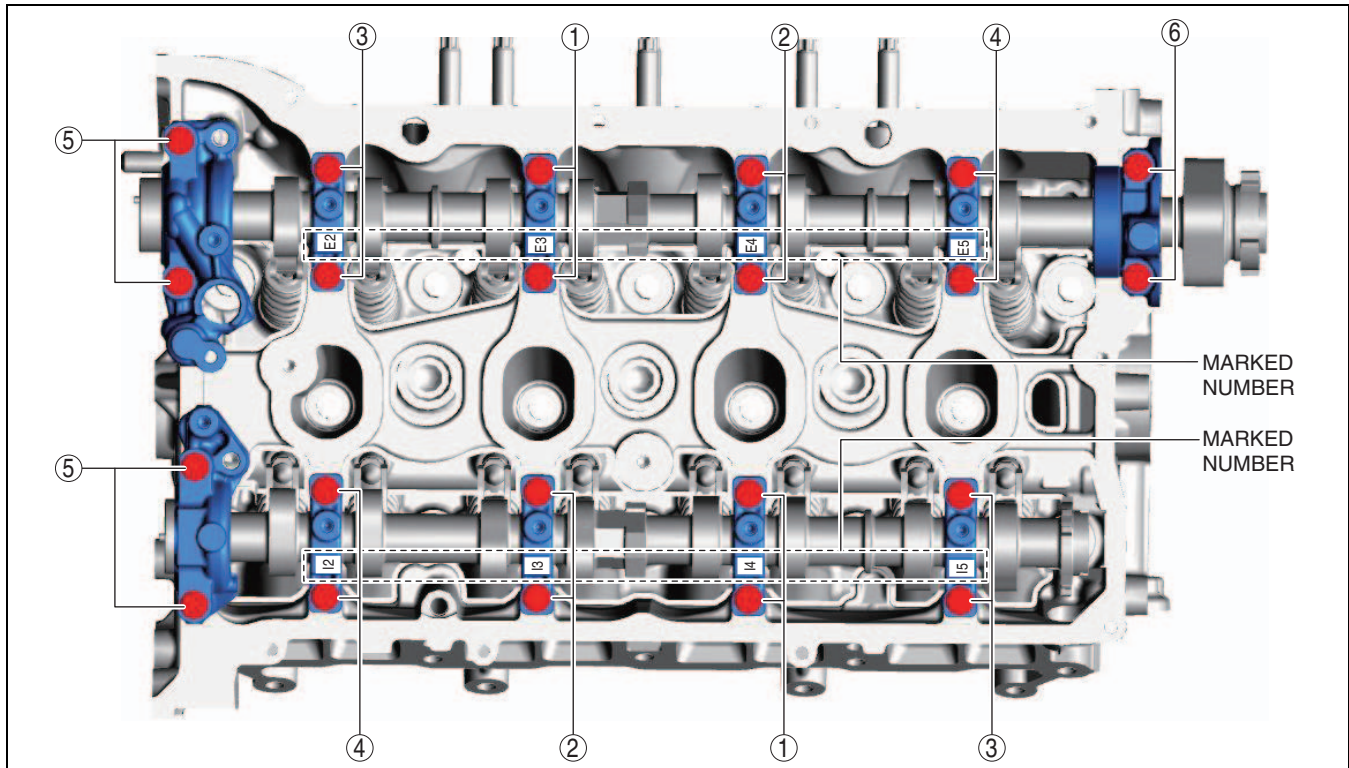

bp25ue00000043

MECHANICAL

Tightening torque

Step 1: 3.0—6.0 N·m {31—61 kgf·cm, 27—53 in·lbf}

Step 2: 8—11 N·m {82—112 kgf·cm, 71—97 in·lbf}

Electric Variable Valve Timing Actuator, Hydraulic Variable Valve Timing Actuator Assembly Note

1. Align the knock pin on the end of the camshaft with the notch on the actuator (intake side) or knock pin installation hole (exhaust side), then install the actuator to the camshaft.

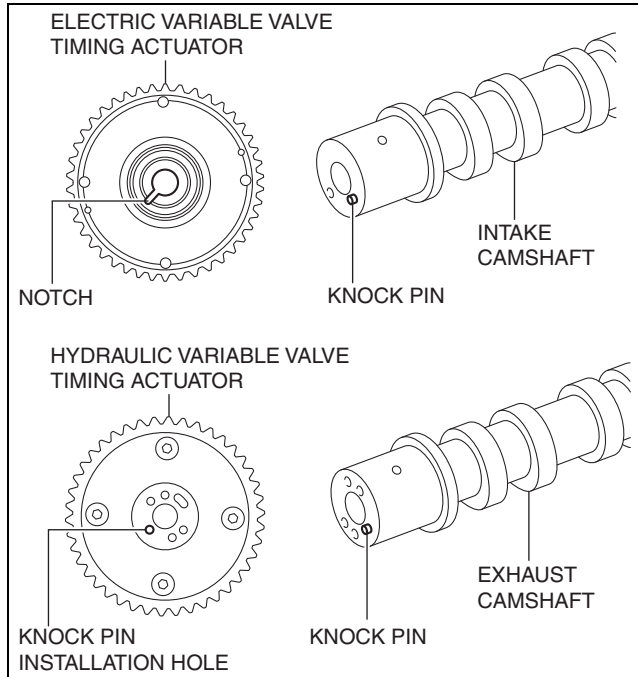

bpe2ue0000072

2. Hold the camshaft using a wrench on the cast hexagon, and tighten the actuator installation bolt.

Tightening torque

Electric variable valve timing actuator
(intake side): 102—114 N·m {10.5—11.6 kgf·m, 76—84 ft·lbf}

Hydraulic variable valve timing actuator
(exhaust side): 75—85 N·m {7.7—8.6 kgf·m, 56—62 ft·lbf}

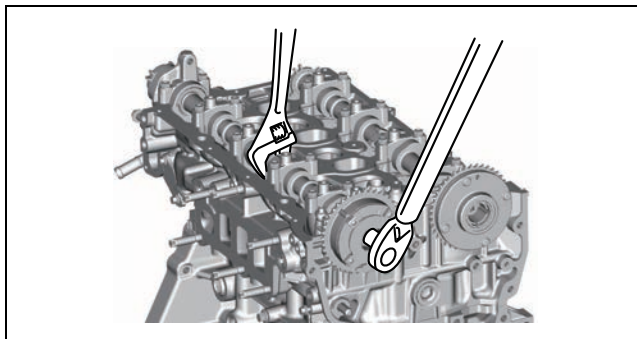

bp25ue0000044

TIMING CHAIN ASSEMBLY

id011000505600

Special Service Tool (SST)

1. : Mazda SST number 2. : Global SST number	
1: 49 E011 1A0 2: - Ring gear brake set	1: 49 H00 401 2: - Oil seal installer

01-10

Caution

- If the camshaft is rotated with the timing chain removed and the piston at the top dead center position, the valve may contact the piston and the engine could be damaged. When rotating the camshaft with the timing chain removed, rotate it after lowering the piston from the top dead center position.
- When rotating the camshaft using a wrench on the cast hexagon, the wrench may contact the rocker arm and damage the rocker arm. To prevent damage to the rocker arm when holding the camshaft on the cast hexagon, use a wrench on the rear side of the engine as shown in the figure to secure a clearance between the cam.
- When installing the oil pan, refer to the Oil Pan Installation Note and apply the silicone sealant correctly. If the silicone sealant application position is incorrect or there is any break in the application track, engine oil leakage will occur due to a poor seal.

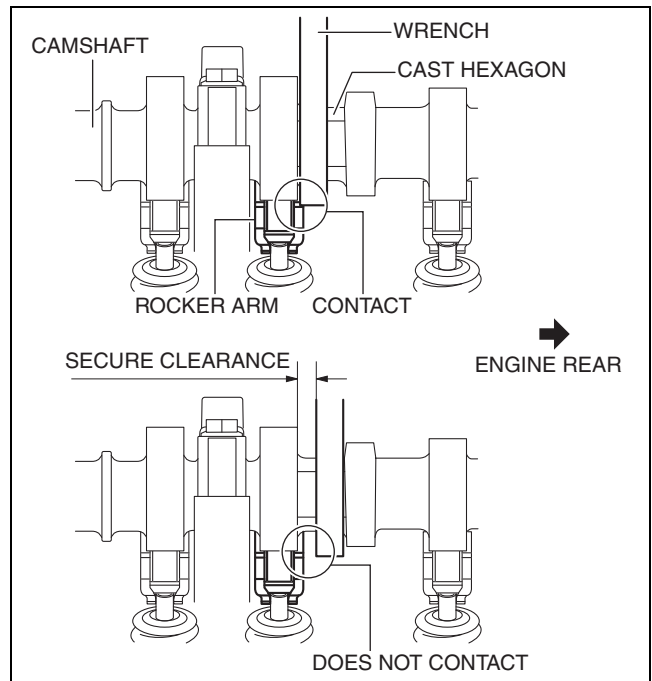

am3uuw0000896

Note

- Width at the cast hexagon of the camshaft is 22—24 mm {0.87—0.94 in}.

1. Assemble in the order indicated in the table.

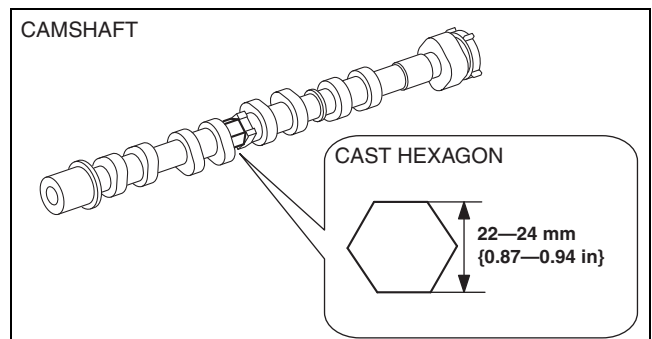

bpe5ue00000032

MECHANICAL

U.S.A. and CANADA

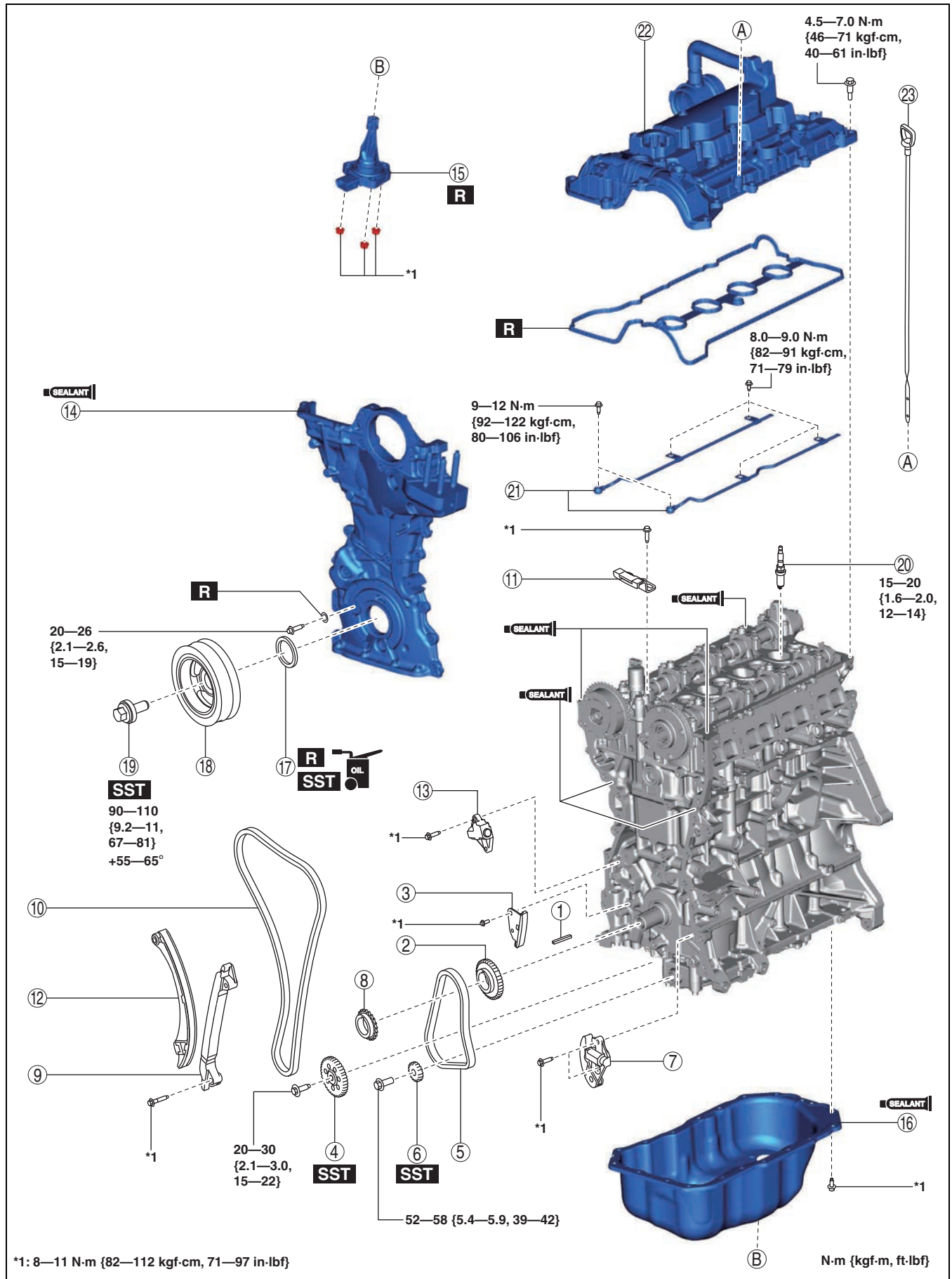

bp25ue0000054

MECHANICAL

1	Key
2	Oil pump drive sprocket
3	Oil pump chain guide
4	Oil pump driven sprocket (See 01-10-66 Oil Pump Chain Assembly Note.)
5	Oil pump chain (See 01-10-66 Oil Pump Chain Assembly Note.)
6	Balancer shaft sprocket (See 01-10-66 Oil Pump Chain Assembly Note.)
7	Oil pump chain tensioner (See 01-10-66 Oil Pump Chain Assembly Note.)
8	Crankshaft sprocket
9	Chain guide (No.2)
10	Timing chain (See 01-10-68 Timing Chain Assembly Note.)
11	Chain guide (No.1) (See 01-10-68 Timing Chain Assembly Note.)
12	Tensioner arm (See 01-10-68 Timing Chain Assembly Note.)

13	Chain tensioner (See 01-10-68 Timing Chain Assembly Note.)
14	Engine front cover (See 01-10-70 Engine Front Cover Assembly Note.)
15	Oil level sensor
16	Oil pan (See 01-10-74 Oil Pan Assembly Note.)
17	Front oil seal (See 01-10-76 Front Oil Seal Assembly Note.)
18	Crankshaft pulley
19	Crankshaft pulley lock bolt (See 01-10-77 Crankshaft Pulley Lock Bolt Assembly Note.)
20	Spark plug
21	Oil shower pipe (See 01-10-77 Oil Shower Pipe Assembly Note.)
22	Cylinder head cover (See 01-10-77 Cylinder Head Cover Assembly Note.)
23	Dipstick

Oil Pump Chain Assembly Note

1. Verify that the key and knock pin are aligned to the positions shown in the figure.
 - If they are not in the positions shown in the figure, rotate the crankshaft and balancer shaft (No.1) to set cylinder No.1 to top dead center (TDC).
 2. Temporarily assemble the oil pump driven sprocket.
 3. Temporarily tighten the oil pump driven sprocket installation bolt.
-
4. Align the oil pump chain alignment mark with the balancer shaft sprocket alignment mark.

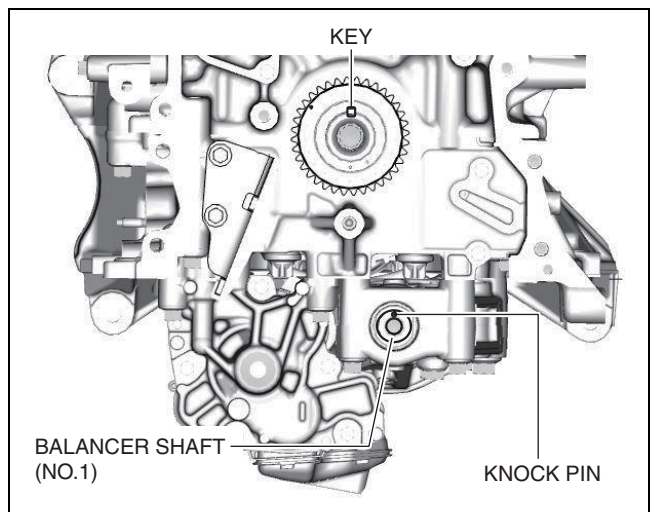

bp25ue0000056

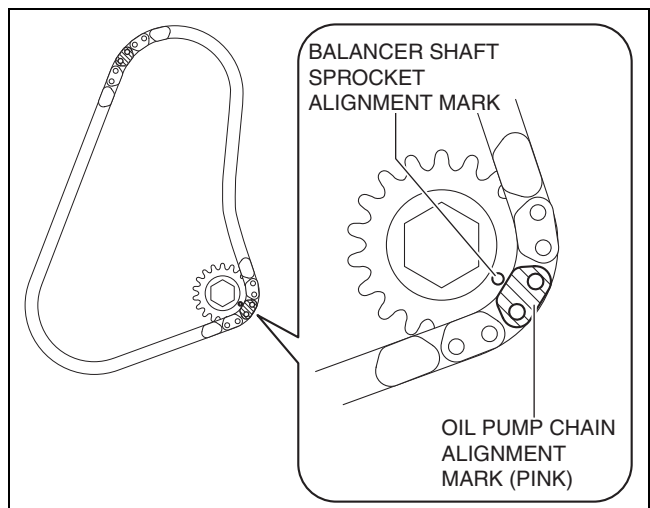

bp25ue0000057

MECHANICAL

5. Install the oil pump chain and balancer shaft sprocket as a single unit while aligning the alignment marks on each sprocket and oil pump chain as shown in the figure.

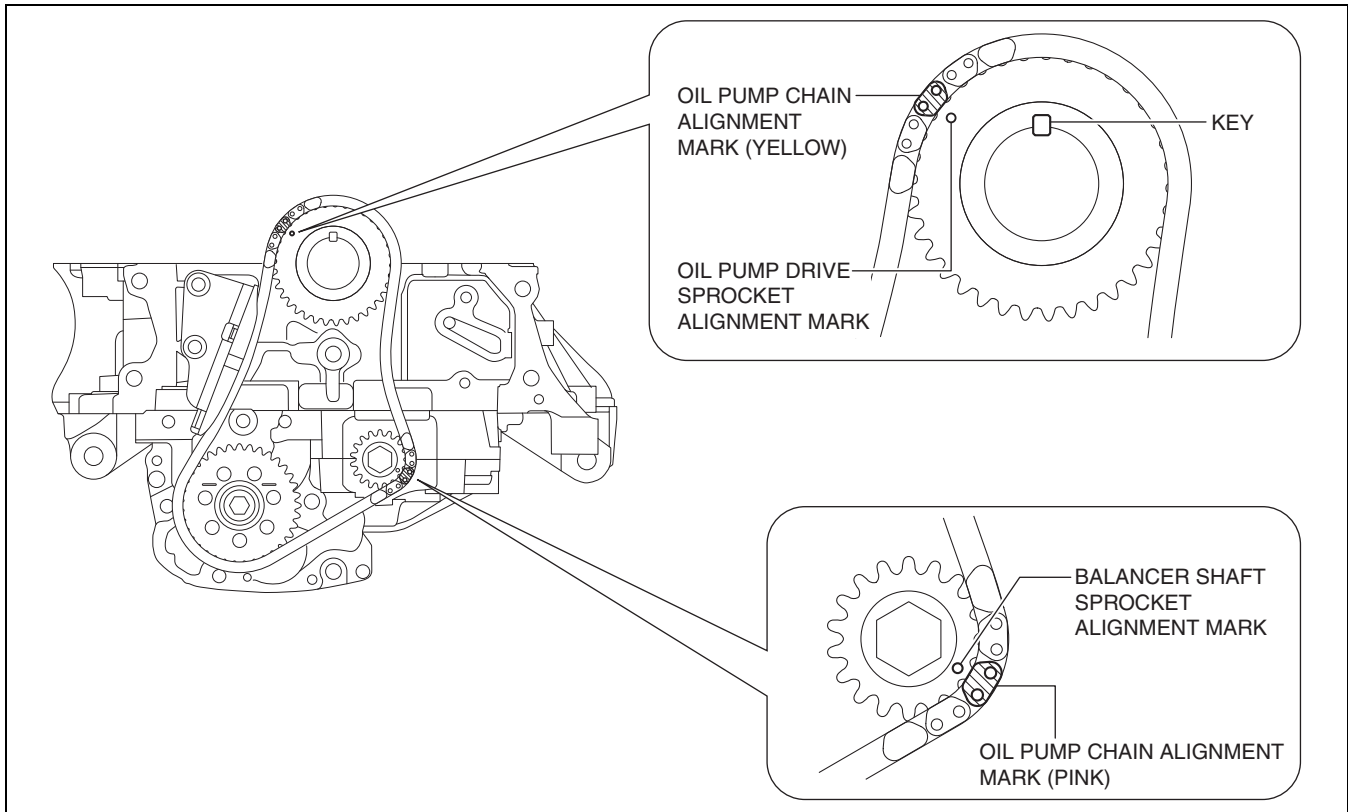

01-10

bp25ue0000058

6. Temporarily tighten the balancer shaft sprocket installation bolt.
7. Install the oil pump chain tensioner.

Caution

- At this stage, do not remove the wire or paper clip installed to the oil pump chain tensioner.

8. Hold the crankshaft using the SST.
9. Tighten the oil pump driven sprocket installation bolt.

Tightening torque

20—30 N·m {2.1—3.0 kgf·m, 15—22 ft·lbf}

10. Tighten the balancer shaft sprocket installation bolt.

Tightening torque

52—58 N·m {5.4—5.9 kgf·m, 39—42 ft·lbf}

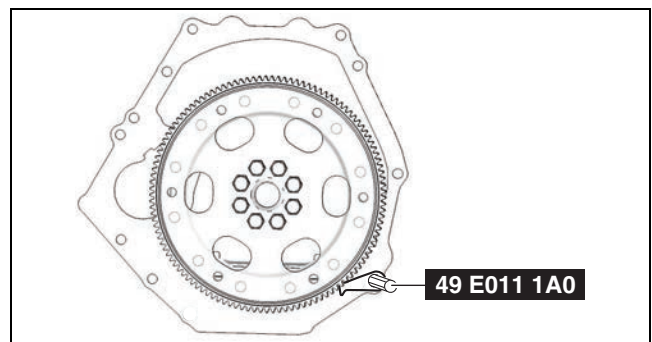

bp25ue0000094

11. Remove the wire or paper clip installed to the oil pump chain tensioner and apply tension to the oil pump chain.
 - If a new oil pump chain tensioner is used, remove the installed stopper.

MECHANICAL

Timing Chain Assembly Note

1. Verify that the timing marks and the key are aligned to the position shown in the figure.

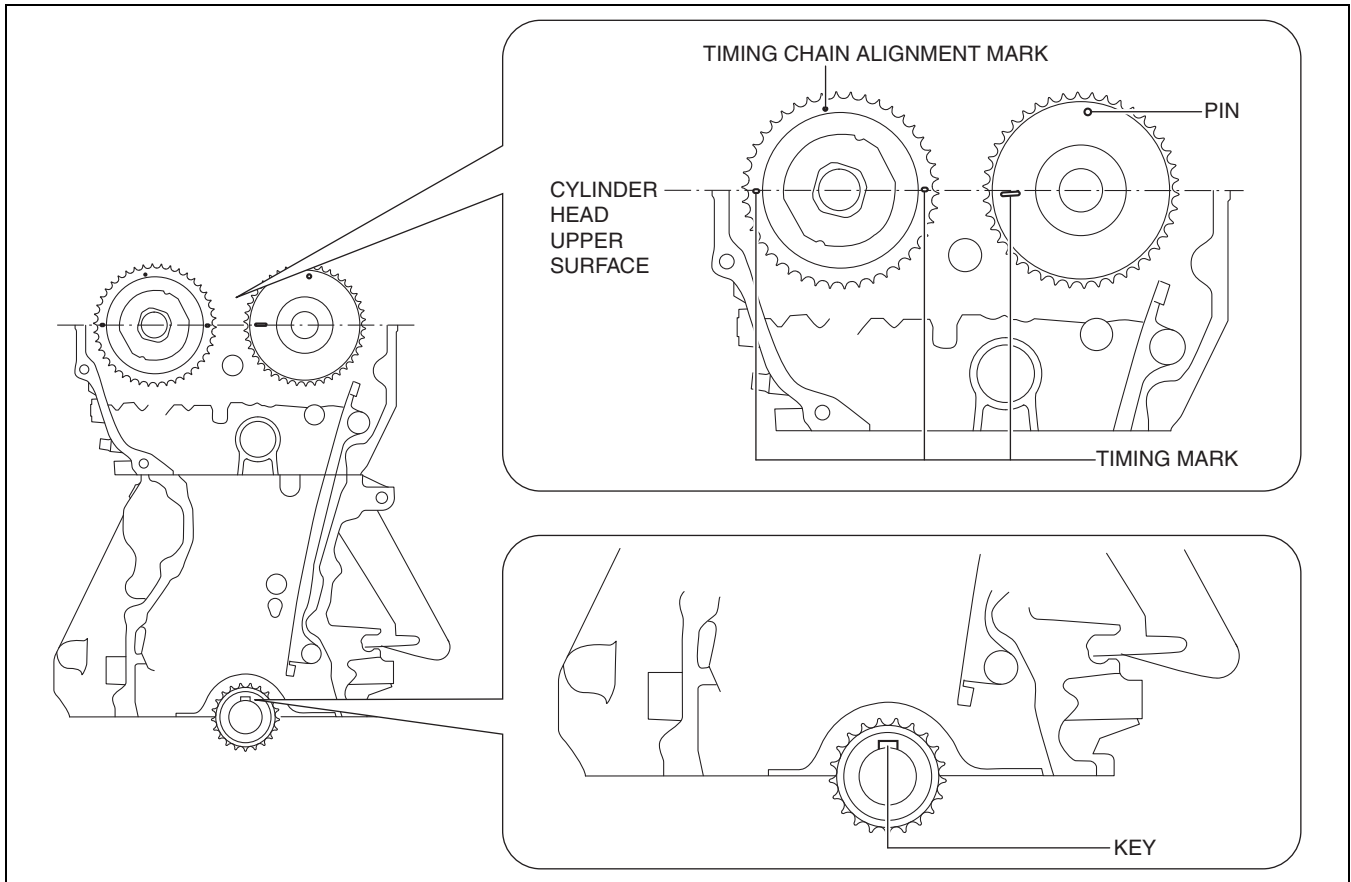

bp25ue0000060

Note

- The timing mark of SKYACTIV-G 2.5T is not completely parallel with the upper surface of the cylinder head.
- If they are not in the position shown in the figure, rotate the camshaft and crankshaft to set the cylinder No.1 top dead center (TDC).

MECHANICAL

2. Install the timing chain while aligning the marks on each sprocket and the timing chain as shown in the figure.

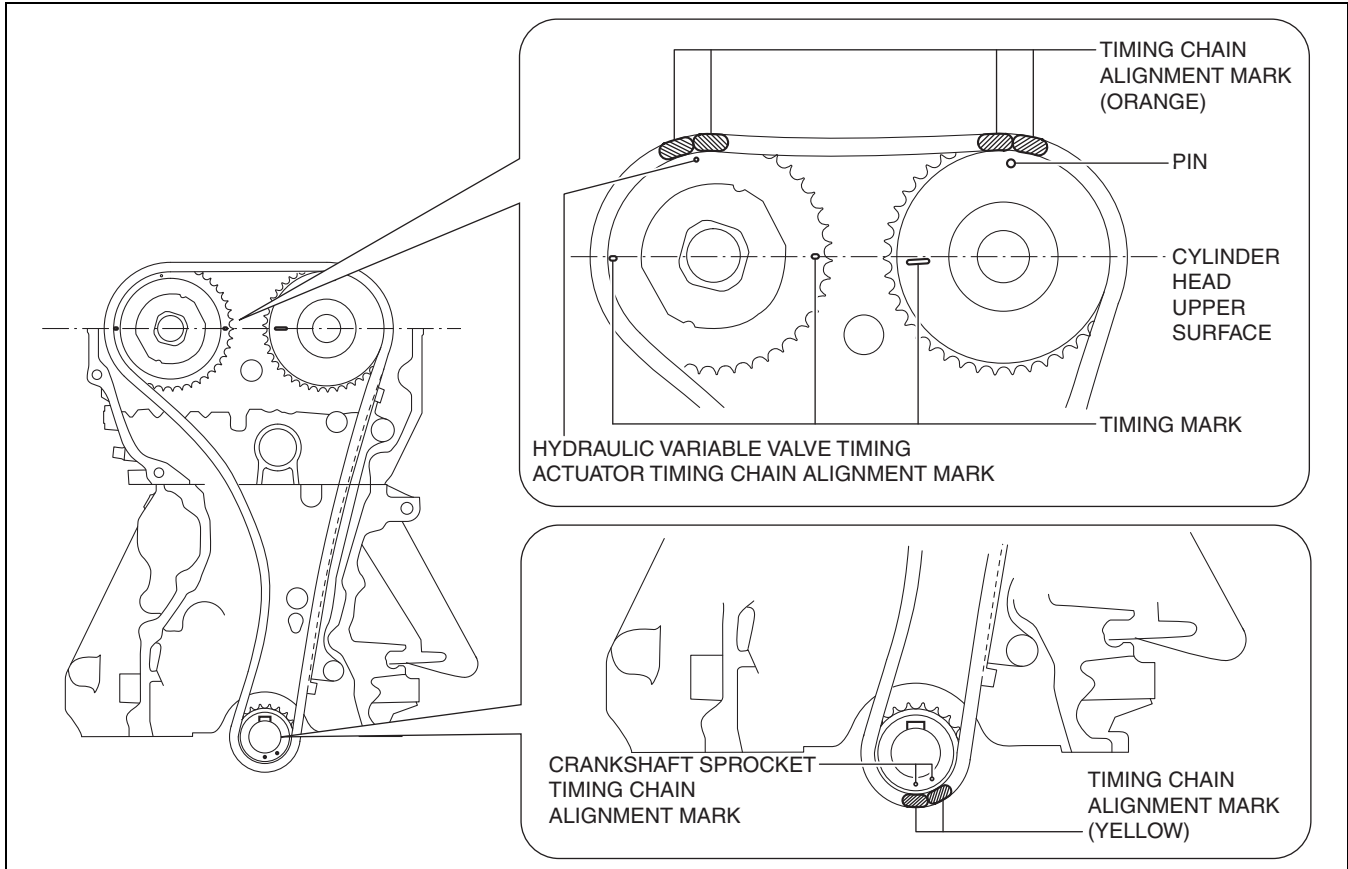

bp25ue0000061

3. Install the tensioner arm.
4. Install the chain tensioner.
5. After installing the chain tensioner, remove the installed wire or paper clip, and then apply tension to the timing chain. (Chain tensioner type A)
 - If a new chain tensioner is used, remove the installed stopper.

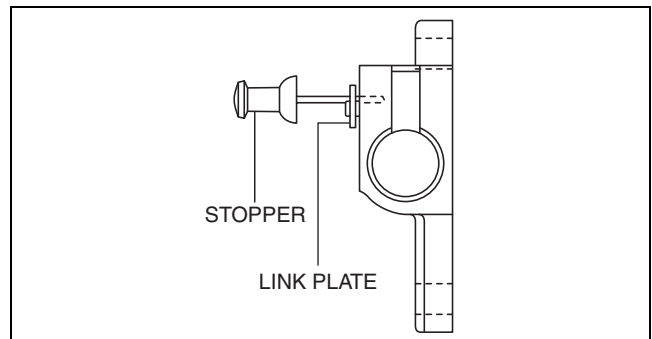

am3uuw0000886

6. After installing the timing chain tensioner, remove the installed rod, and then apply tension to the timing chain. (Chain tensioner type B)
 - If a new chain tensioner is used, remove the installed lock pin.
7. Install the chain guide (No.1).
8. Verify that there is no looseness in the timing chain, and re-verify that each sprocket is in the specified location.

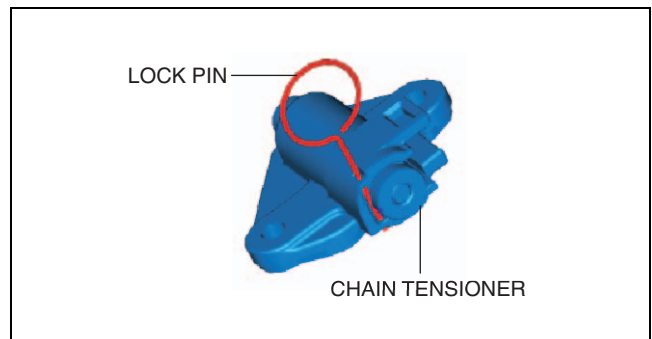

amxuuw0000441

01-10

MECHANICAL

9. Rotate the crankshaft clockwise two turns and inspect the valve timing.

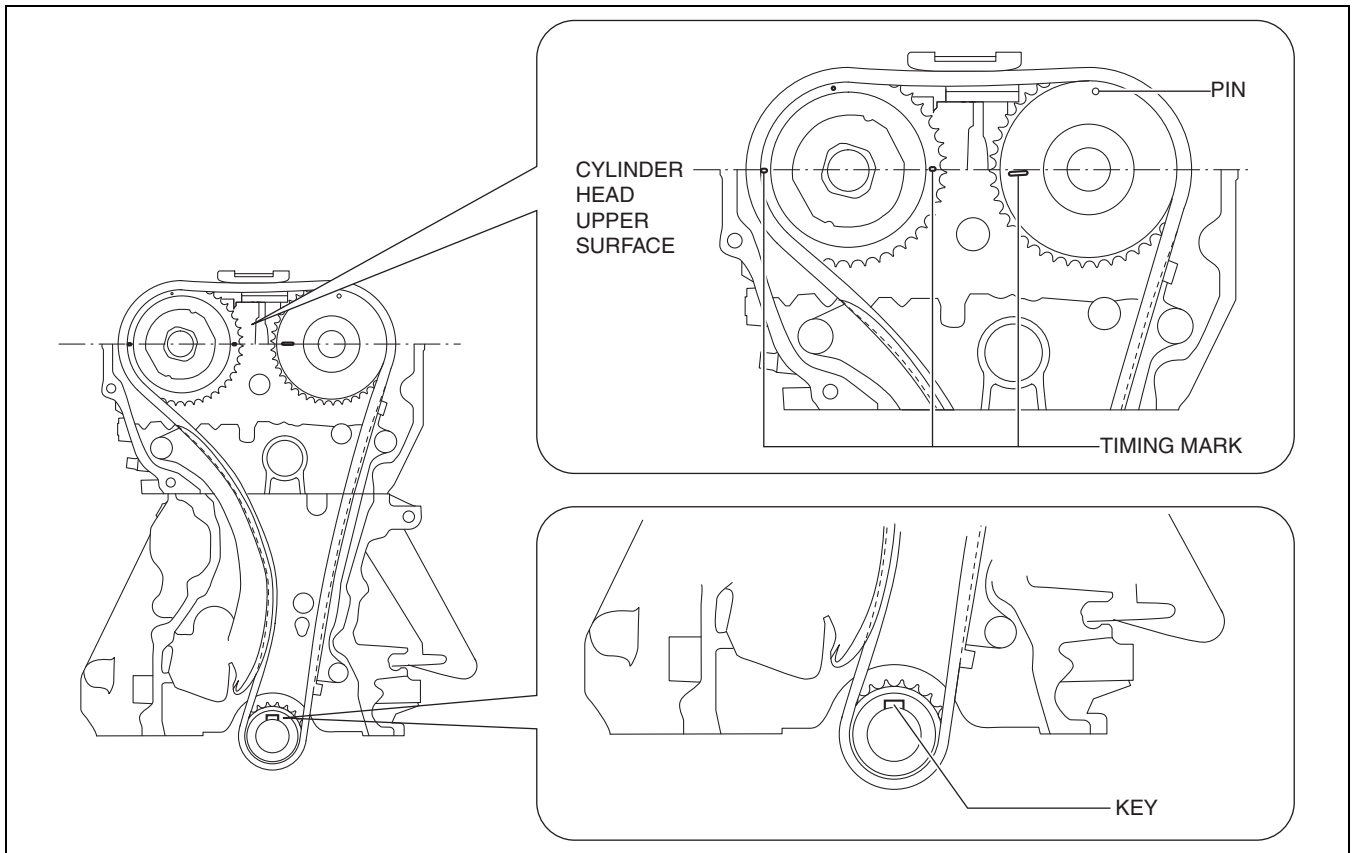

bp25ue0000062

Note

- The timing mark of SKYACTIV-G 2.5T is not completely parallel with the upper surface of the cylinder head.

Engine Front Cover Assembly Note

Note

- For a new engine front cover, the positioning pins in the two locations shown in the figure project to the outside of the engine.

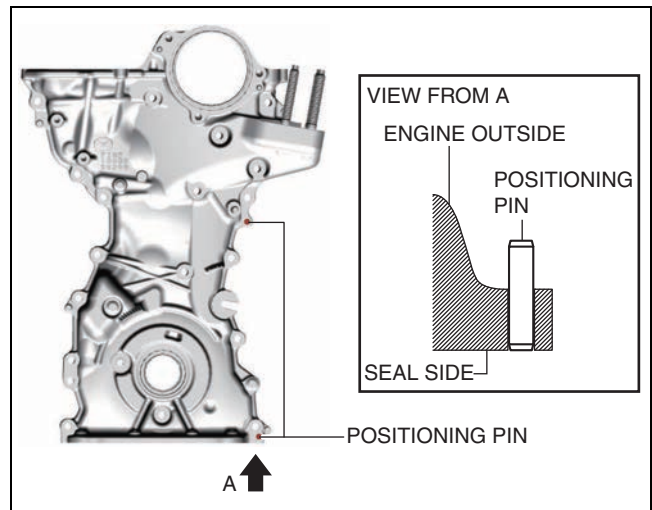

bp25ue0000063

MECHANICAL

1. If the engine front cover is newly replaced, tap the positioning pins in the two locations to the seal surface side.
2. When reusing the engine front cover installation bolts, remove silicone sealant adhering to the bolts.

Caution

- If a bolt with silicone sealant adhering to it is used, it could result in cracks in the cylinder head and cylinder block.

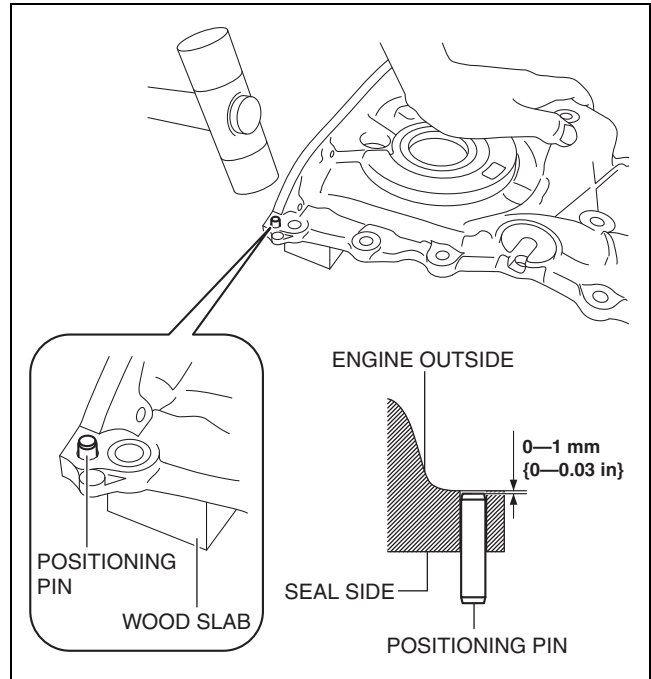

bpe5ue00000033

3. Completely clean and remove oil, dirt, silicone sealant or other foreign matter that may be adhering to the engine front cover, cylinder head, and cylinder block.

Caution

- If oil, dirt and silicone sealant remains on the silicone sealant application area, the silicone sealant will not seal which will cause oil leakage.
- Apply the silicon sealant in a single, unbroken line.
- To prevent silicone sealant from hardening, adhere the engine front cover and the cylinder block firmly within 10 min. after applying silicone sealant. After adhering them, tighten the installation bolts immediately.

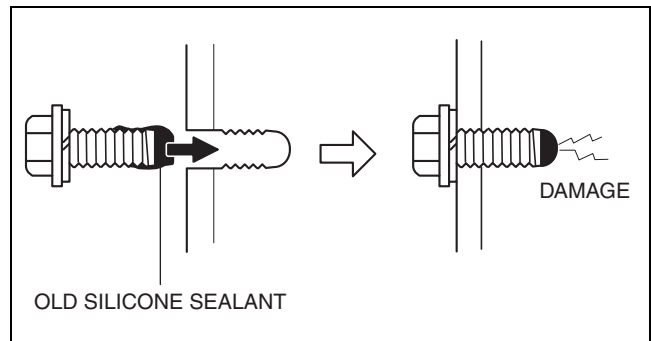

bpe5ue00000046

01-10

MECHANICAL

4. Apply silicone sealant (TB1217D or equivalent) to the engine front cover as shown in the figure.

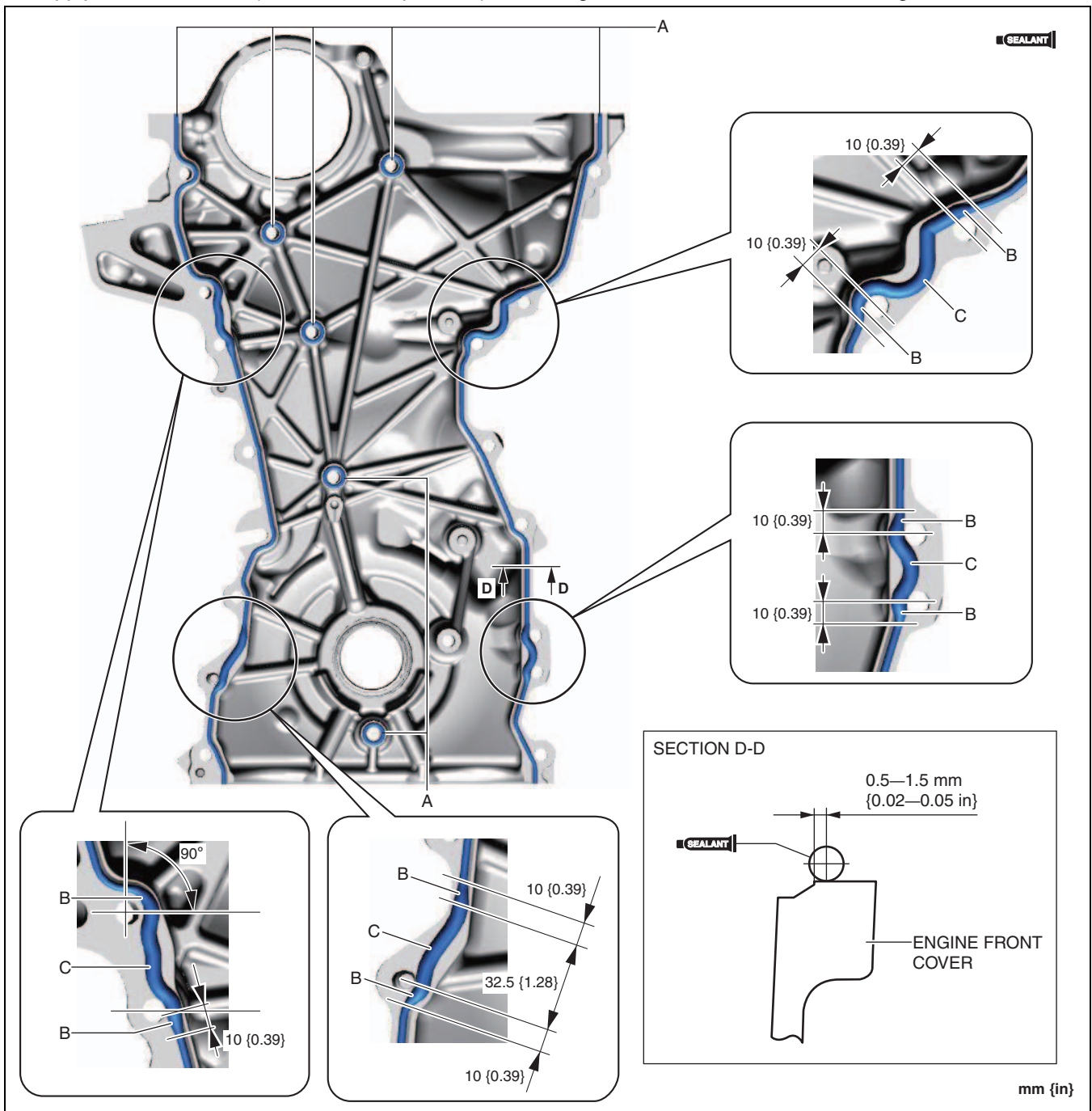

mm {in} bp25ue0000064

Thickness

- A: 2—6 mm {0.1—0.2 in}
- B: 4—6 mm {0.16—0.23 in}
- C: 4—8 mm {0.2—0.3 in}

MECHANICAL

5. Apply silicone sealant to the areas shown in the figure.

Caution

- Apply the silicone sealant so that it goes into the cylinder head gasket.

6. Install the engine front cover to the engine.

Note

- Temporarily install an appropriate bolt to the drive belt auto tensioner installation bolt hole to prevent:
 - A silicone sealant adhesion malfunction in the drive belt auto tensioner installation bolt hole.
 - A bolt mis-installation due to silicone sealant hardening.

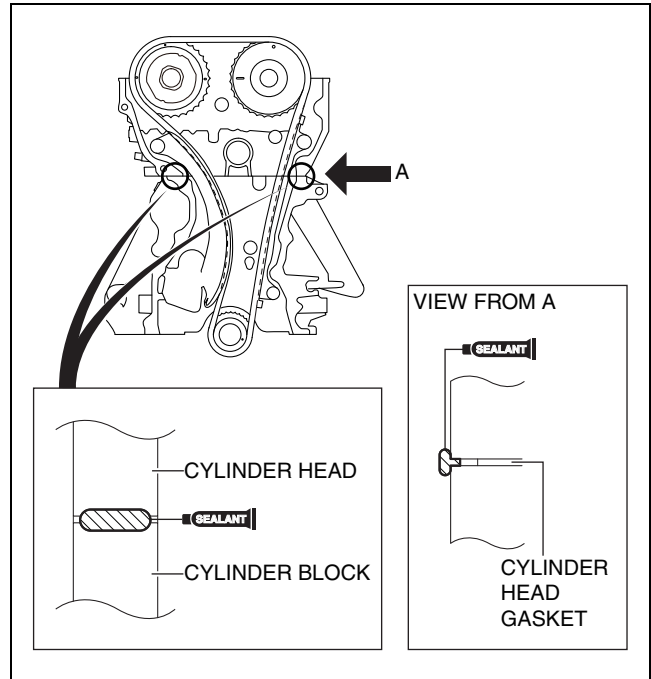

bp25ue0000065

7. Prepare an appropriate **M8 × 1.25** bolt (length **40 mm {1.6 in}**).

Caution

- For the number 10 bolt of the tightening order, install the bolts with new washer.

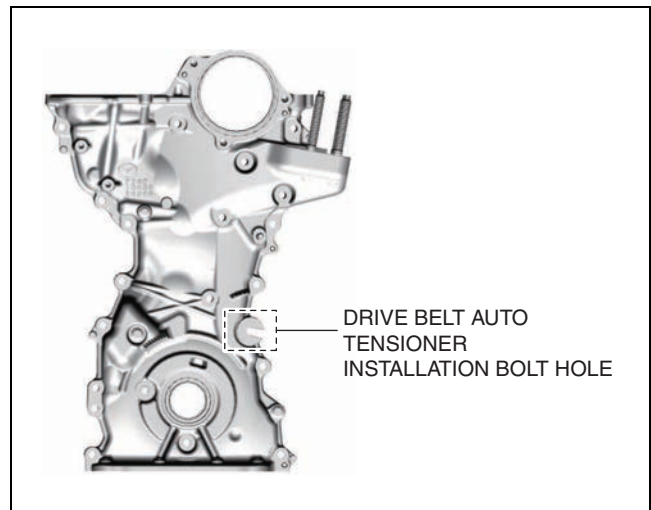

bp25ue0000066

01-10

MECHANICAL

8. Tighten the engine front cover installation bolts in the order shown in the figure.

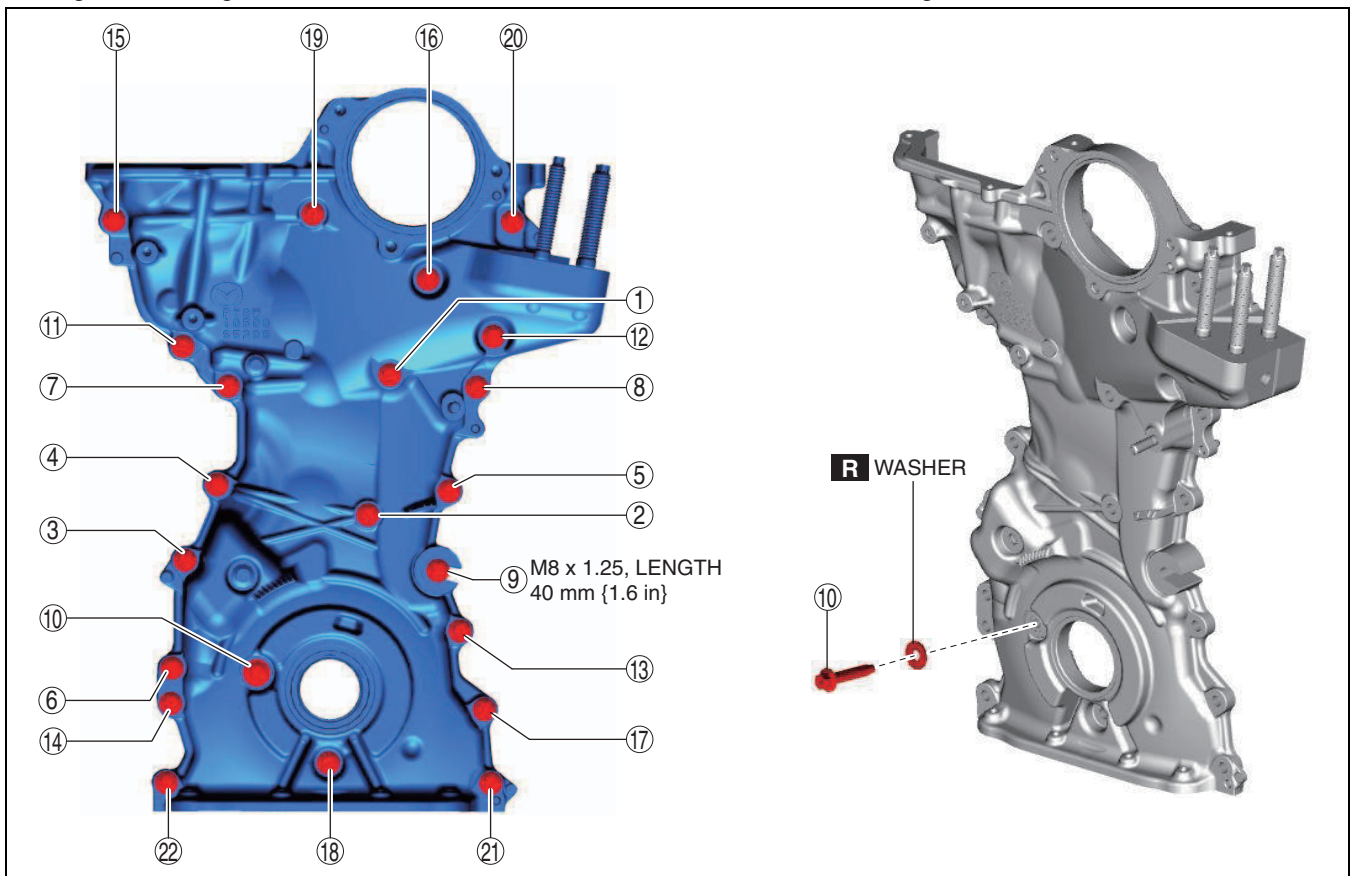

Tightening torque

20—26 N·m {2.1—2.6 kgf·m, 15—19 ft·lbf}

9. Remove the bolt installed to the drive belt auto tensioner installation bolt hole when installing the drive belt auto tensioner.

Oil Pan Assembly Note

1. Completely clean and remove any oil, dirt, sealant or other foreign matter that may be adhering to the cylinder block and oil pan.
2. When reusing the oil pan installation bolts, clean any old sealant from the bolts.

Caution

- Apply the silicon sealant in a single, unbroken line around the whole perimeter.
- To prevent silicone sealant from hardening, adhere the oil pan to the cylinder block within 10 min. after silicone sealant is applied. Tighten the installation bolts completely soon after adhering.
- Using bolts with the old silicone sealant adhering could cause cracks in the cylinder block.

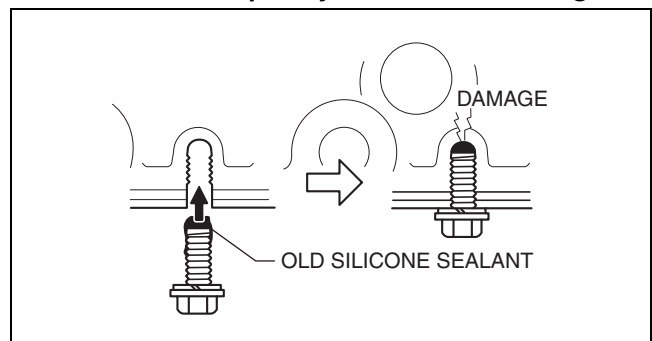

MECHANICAL

3. Apply silicone sealant to the oil pan along the inside of the bolt holes as shown in the figure.

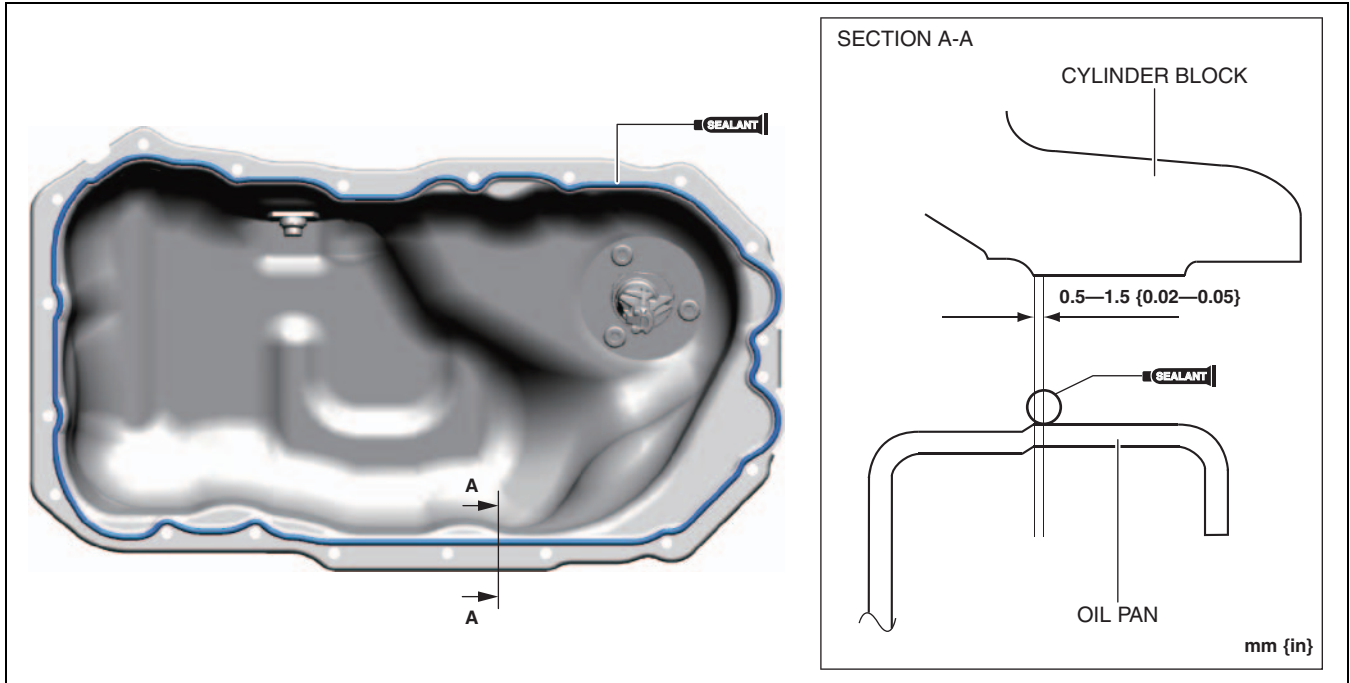

01-10

bp25ue0000068

Thickness

3.0—7.0 mm {0.12—0.27 in}

4. Install the oil pan using the following procedure:
- (1) Install the oil pan to the cylinder block.
 - (2) Temporarily tighten the two bolts shown in the figure.

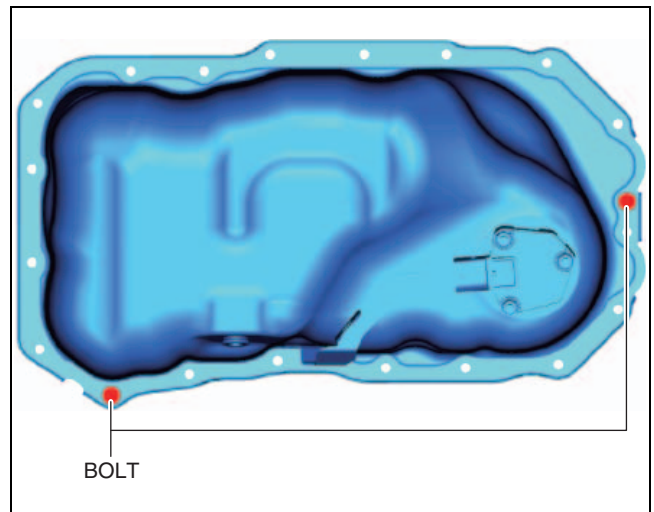

bp25ue0000069

MECHANICAL

(3) Tighten the bolts in the order shown in the figure.

Tightening torque

8—11 N·m {82—112 kgf·cm, 71—97 in·lbf}

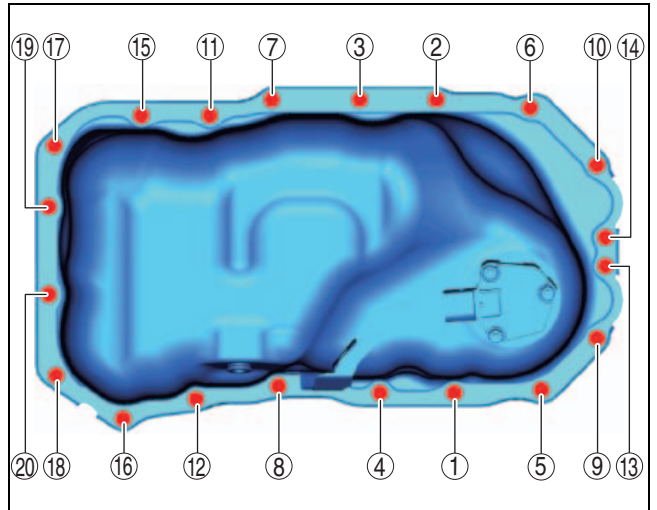

bp25ue0000070

Front Oil Seal Assembly Note

1. Apply clean engine oil to the inner surface of a new front oil seal.
2. Insert the front oil seal into the engine front cover by hand.
3. Tap the oil seal in evenly using the **SST** and a hammer.

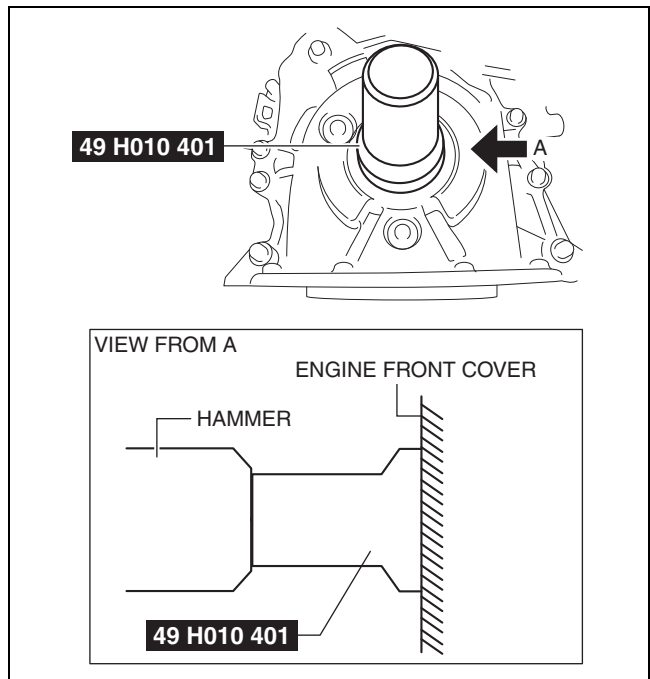

bp25ue0000071

Front oil seal press on amount
 0—1.0 mm {0—0.039 in}

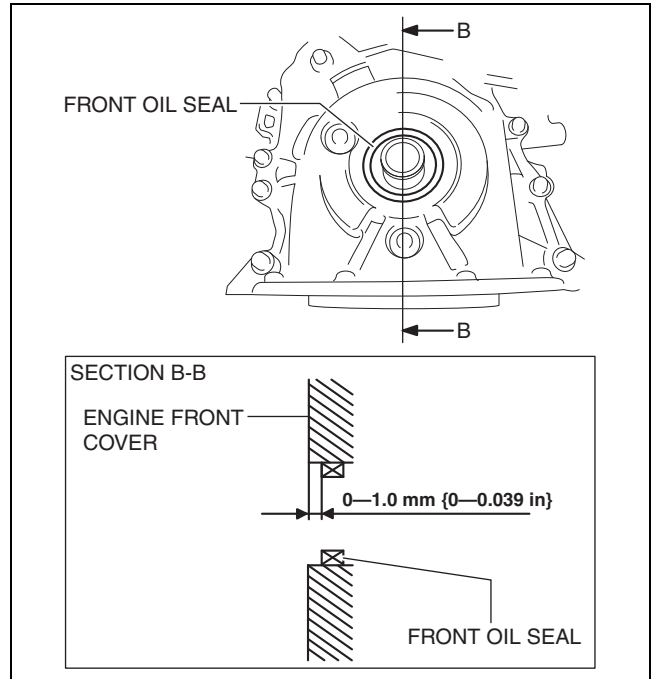

01-10

bp5ue0000037

Crankshaft Pulley Lock Bolt Assembly Note

1. Hold the crankshaft using the **SST**.
2. Tighten the crankshaft pulley lock bolt in the order shown in the following two steps.

Tightening procedure

- Step 1:** 90—110 N·m {9.2—11 kgf·m, 67—81 ft·lbf}
- Step 2:** 55—65°

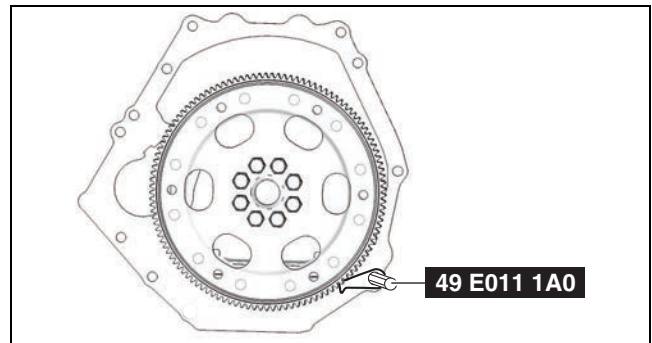

bp25ue0000094

Oil Shower Pipe Assembly Note

1. Install the oil shower pipe in the order shown in the figure.

Tightening torque

Installation position	Tightening torque
1	9—12 N·m {92—122 kgf·cm, 80—106 in·lbf}
2, 3	8.0—9.0 N·m {82—91 kgf·cm, 71—79 in·lbf}

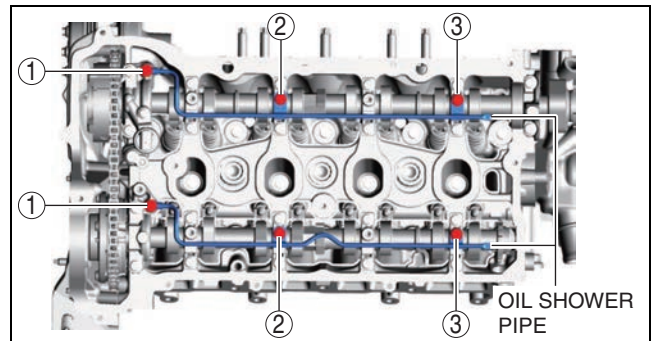

bp25ue0000072

MECHANICAL

Cylinder Head Cover Assembly Note

Caution

- To assure the sealing performance of the cylinder head cover, be careful of the following:
 - Verify that the cylinder head cover gasket is inserted into the cylinder head cover groove and install the cylinder head cover.
 - Completely clean and remove any oil, dirt, sealant or other foreign matter from the seal surface.
- To prevent silicone sealant from hardening, adhere the cylinder head cover and the cylinder head within 10 min. after silicone sealant is applied. Tighten the installation bolts completely soon after adhering.

1. Insert a new cylinder head cover gasket into the cylinder head cover groove.
2. Apply silicone sealant to the areas shown in the figure.

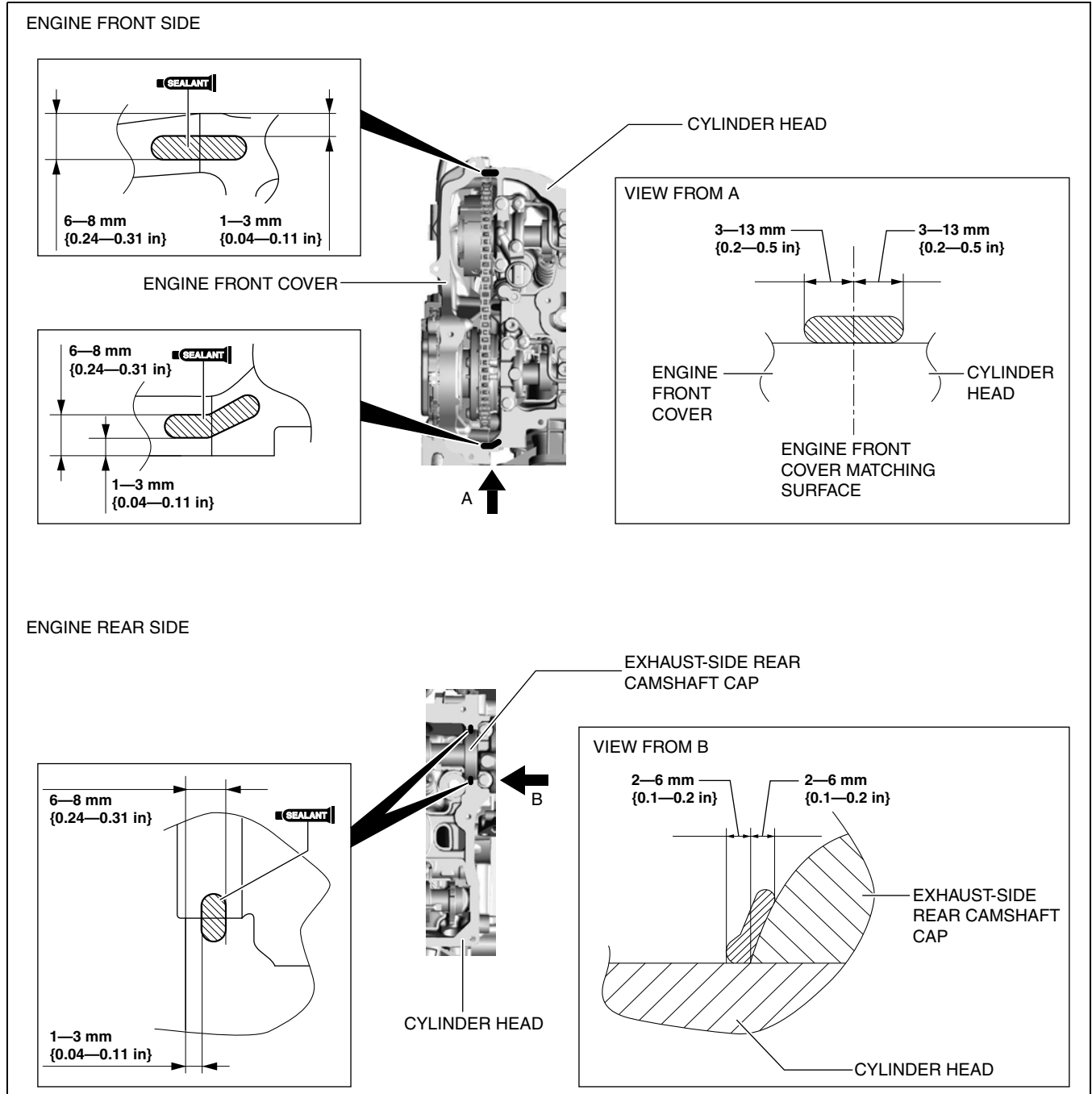

bp25ue0000073

MECHANICAL

3. Tighten the cylinder head cover bolts in the order shown in the figure.
U.S.A. and CANADA

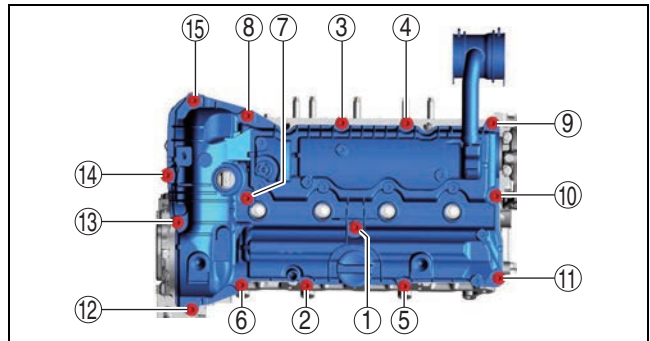

bp25ue0000074

01-10

Except U.S.A. and CANADA

Tightening torque
4.5—7.0 N·m {46—71 kgf·cm, 40—61 in·lbf}

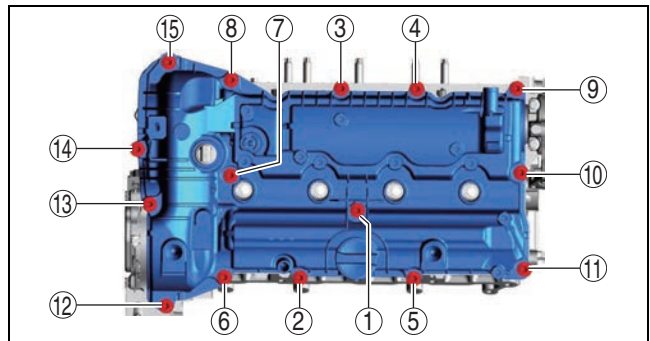

bp25ue0000075

TECHNICAL DATA

01-50 TECHNICAL DATA

ENGINE TECHNICAL DATA 01-50-1

ENGINE TECHNICAL DATA

id015000800100

01-50

Item	Specification
OCV coil resistance	6.9—7.5 ohms [20°C {68°F}]
Maximum distortion, head gasket side of the cylinder head	0.05 mm {0.002 in}
Maximum distortion, manifold side	IN: 0.10 mm {0.0039 in} EX: 0.05 mm {0.002 in}
Maximum cutting length, manifold side	IN: Cutting not authorized EX: 0.20 mm {0.0079 in}
Standard valve seat contact width	1.37—1.84 mm {0.0540—0.0724 in}
Valve seat angle	45°
Standard valve seat sinkage amount (Dimension L)	IN: 48.93—50.17 mm {1.927—1.975 in} EX: 48.87—50.11 mm {1.925—1.972 in}
Standard valve head margin thickness	IN: 1.75—1.95 mm {0.0689—0.0767 in} EX: 1.90—2.10 mm {0.0749—0.0826 in}
Standard valve length	IN: 107.00—107.60 mm {4.2127—4.2362 in} EX: 117.04—117.64 mm {4.6079—4.6314 in}
Minimum valve length	IN: 106.78 mm {4.2039 in} EX: 116.87 mm {4.6012 in}
Standard valve stem diameter	IN: 5.470—5.485 mm {0.2154—0.2159 in} EX: 5.465—5.480 mm {0.2152—0.2157 in}
Minimum valve stem diameter	IN: 5.424 mm {0.2135 in} EX: 5.419 mm {0.2133 in}
Standard valve guide inner diameter	IN: 5.510—5.530 mm {0.2170—0.2177 in} EX: 5.510—5.530 mm {0.2170—0.2177 in}
Standard clearance between valve stem and guide	IN: 0.025—0.060 mm {0.0010—0.0023 in} EX: 0.030—0.065 mm {0.0012—0.0025 in}
Maximum clearance between valve stem and guide	0.10 mm {0.0039 in}
Standard valve guide projection height	IN: 16.4—17.0 mm {0.646—0.669 in} EX: 16.4—17.0 mm {0.646—0.669 in}
Valve spring installation height	IN: When pressurized with spring force of 195—215 N {19.9—21.9 kgf, 43.9—48.3 lbf}, spring height is 38.0 mm {1.50 in} EX: When pressurized with spring force of 228—252 N {23.3—25.6 kgf, 51.3—56.6 lbf}, spring height is 38.0 mm {1.50 in}
Maximum valve spring off-square	IN: 2.0 ° (3.6 mm {0.14 in}) EX: 2.0 ° (3.6 mm {0.14 in})
Maximum camshaft runout	0.030 mm {0.0012 in}
Standard cam height	IN: 42.34 mm {1.667 in} EX: 40.35 mm {1.589 in}
Minimum cam height	IN: 42.27 mm {1.664 in} EX: 40.28 mm {1.586 in}
Standard camshaft journal diameter	24.96—24.98 mm {0.9827—0.9834 in}
Minimum camshaft journal diameter	24.93 mm {0.9815 in}
Standard camshaft journal oil clearance	0.035—0.080 mm {0.0014—0.0031 in}
Maximum camshaft journal oil clearance	0.090 mm {0.0035 in}
Standard camshaft end play	0.07—0.22 mm {0.003—0.008 in}
Maximum camshaft end play	0.98 mm {0.039 in}
Maximum distortion, head gasket side of the cylinder block	0.10 mm {0.0039 in}
Standard cylinder bore diameter	89.000—89.030 mm {3.5040—3.5051 in}
Oil jet valve opening pressure	180—220 kPa {1.84—2.24 kgf/cm ² , 26.2—31.9 psi}
Standard piston outer diameter	88.965—88.995 mm {3.5026—3.5037 in}
Standard clearance between piston and cylinder	0.025—0.045 mm {0.0010—0.0017 in}
Maximum clearance between piston and cylinder	0.066 mm {0.0026 in}

TECHNICAL DATA

Item	Specification
Standard clearance between piston ring and ring groove	Top: 0.04—0.08 mm {0.002—0.003 in} Second: 0.03—0.07 mm {0.0012—0.0027 in} Oil: 0.04—0.12 mm {0.002—0.004 in}
Maximum clearance between piston ring and ring groove	Top: 0.12 mm {0.0047 in} Second: 0.10 mm {0.0039 in} Oil: 0.17 mm {0.0067 in}
Standard piston ring end gap	Top: 0.13—0.18 mm {0.0052—0.0070 in} Second: 0.18—0.28 mm {0.008—0.011 in} Oil (Rail): 0.10—0.35 mm {0.004—0.013 in}
Maximum piston ring end gap	Top: 0.35 mm {0.014 in} Second: 0.45 mm {0.018 in} Oil (Rail): 0.52 mm {0.020 in}
Standard piston pin outer diameter	22.495—22.500 mm {0.88564—0.88582 in}
Standard piston pin hole diameter	22.504—22.508 mm {0.88599—0.88614 in}
Standard clearance between piston pin hole diameter and piston pin outer diameter	0.004—0.013 mm {0.0002—0.0005 in}
Standard connecting rod small end inner diameter	22.502—22.513 mm {0.88591—0.88633 in}
Standard clearance between connecting rod small end inner diameter and piston pin outer diameter	0.002—0.018 mm {0.00008—0.00070 in}
Maximum connecting rod bending	0.050 mm {0.0020 in}
Maximum connecting rod distortion	0.050 mm {0.0020 in}
Connecting rod center-to-center distance	150.32 mm {5.9181 in}
Standard side clearance at the large end of connecting rod	0.14—0.36 mm {0.006—0.014 in}
Maximum side clearance at the large end of connecting rod	0.465 mm {0.0183 in}
Standard bearing oil clearance at the large end of the connecting rod	0.026—0.052 mm {0.0011—0.0020 in}
Maximum bearing oil clearance at the large end of the connecting rod	0.10 mm {0.0039 in}
Connecting rod bearing size (upper)	STD: 1.498—1.516 mm {0.05898—0.05969 in} OS 0.25: 1.624—1.631 mm {0.06394—0.06421 in} OS 0.50: 1.749—1.756 mm {0.06886—0.06913 in}
Connecting rod bearing size (lower)	STD: 1.502—1.519 mm {0.05914—0.05980 in} OS 0.25: 1.628—1.631 mm {0.06410—0.06421 in} OS 0.50: 1.753—1.756 mm {0.06902—0.06913 in}
Standard crankshaft end play	0.08—0.29 mm {0.004—0.011 in}
Maximum crankshaft end play	0.30 mm {0.012 in}
Thrust bearing size	STD: 2.500—2.550 mm {0.0985—0.1003 in} OS 0.25: 2.625—2.675 mm {0.1034—0.1053 in}
Maximum main journal runout	0.10 mm {0.0039 in}
Standard main journal diameter	49.980—50.000 mm {1.9678—1.9685 in}
Maximum main journal off-round	0.005 mm {0.0002 in}
Standard crank pin diameter	49.980—50.000 mm {1.9678—1.9685 in}
Maximum crank pin off-round	0.005 mm {0.0002 in}
Standard main journal oil clearance	0.016—0.039 mm {0.0007—0.0015 in}
Maximum main journal oil clearance	0.084 mm {0.0033 in}
Main bearing size	STD: 2.489—2.510 mm {0.0980—0.0988 in} OS 0.25: 2.614—2.617 mm {0.10292—0.10303 in} OS 0.50: 2.739—2.742 mm {0.10784—0.10795 in}
Standard cylinder head bolt length	145.2—145.8 mm {5.717—5.740 in}
Maximum cylinder head bolt length	146.5 mm {5.768 in}
Standard connecting rod bolt length	43.7—44.3 mm {1.73—1.74 in}
Maximum connecting rod bolt length	45.0 mm {1.77 in}
Rear oil seal press on amount	0—0.5 mm {0—0.019 in}
Front oil seal press on amount	0—1.0 mm {0—0.039 in}