

REMOVAL

1. PLACE FRONT WHEELS FACING STRAIGHT AHEAD
2. REMOVE STEERING WHEEL PAD (See page [SR-13](#))
3. REMOVE STEERING WHEEL (See page [SR-13](#))
4. REMOVE RH AND LH FRONT BRAKE CALIPERS (See page [BR-27](#))
5. DISCONNECT RH AND LH TIE ROD ENDS (See page [SA-34](#))
6. REMOVE NO. 2 ENGINE UNDER COVER
7. DISCONNECT SLIDING YOKE (See page [SR-13](#))

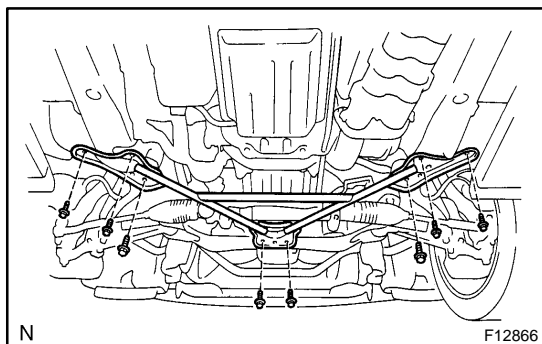

8. REMOVE FRONT SUSPENSION MEMBER BRACE

Remove the 8 bolts and front suspension member brace.

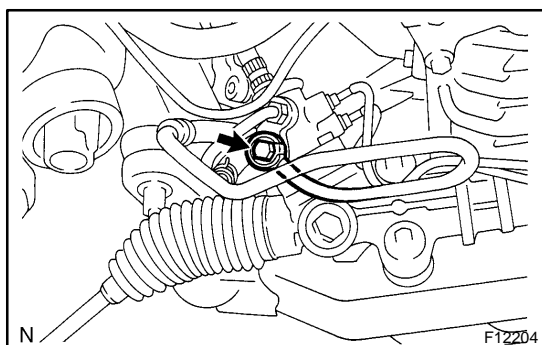

9. DISCONNECT PRESSURE FEED TUBE

Remove the union bolt and gasket, and disconnect the pressure feed tube.

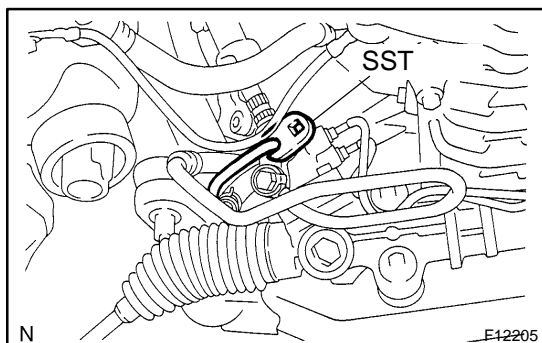

10. DISCONNECT RETURN TUBE

Using SST, disconnect the return tube.

SST 09023-38400

11. REMOVE PS GEAR ASSEMBLY, BRACKET AND GROMMET

Remove the 4 bolts, PS gear assembly, bracket and grommet.